

105 -- "HD 7" Steering Clutches, Brakes and Final Drive Pinion

A. REMOVAL OF BRAKES:

1. Remove seat cushion, batteries, and rear enclosure plate.
2. Shut fuel off under tank by turning shut off cock handle to vertical position.
3. Disconnect fuel lines under tank and remove clamp bolts holding fuel line to fender.

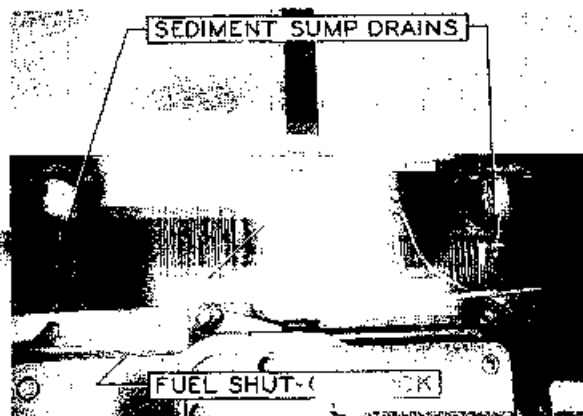

FIG. 1

4. Disconnect both inlet and outlet lines at filter under seat and remove filter by taking out two bolts that hold filter to fender.
5. Remove seat by taking out 3 capscrews on each side holding seat to fuel tank, the 3 bolts holding seat to top fenders,

and the 4 bolts holding seat frame to fender plate.

6. Remove clamp bolt holding return fuel line to rear of seat frame.
7. Remove 3 capscrews and 3 bolts on each side that holds battery rack in place.
8. Remove yoke pins from rear end of steering clutch rods. Fig. 2.

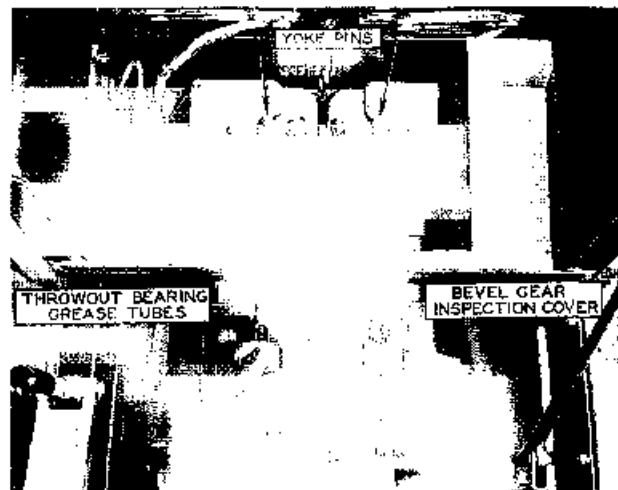
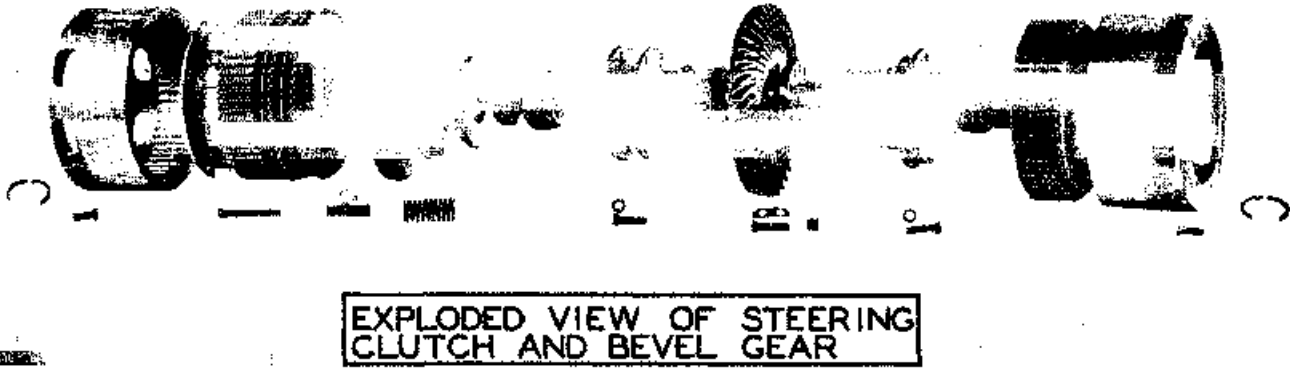

FIG. 2

9. Remove steering clutch inspection covers by removing 6 capscrews.
10. Remove jam nuts from grease tubes which come up through steering clutch



EXPLODED VIEW OF STEERING CLUTCH AND BEVEL GEAR

FIG. 3

- cover assembly. Fig. 2.
11. Loosen steering clutch adjusting screw lock bolts at top of throwout fork and back adjusting screw out far enough to pass by thrust pin.
 12. Remove remaining capscrew which holds steering clutch cover to transmission case and remove this cover.
 13. Lift out steering clutch throwout forks.
 14. Remove equalizers in bottom of each clutch compartment by removing bolt which comes up through bottom of transmission case.
 15. Unhook springs from brake levers; remove pins from bottom brake rods.
 16. Remove one top capscrew and loosen one bottom capscrew on each brake hole cover; then remove covers.

17. Remove brake adjusting nut and pull adjusting bolt out of swivel pin. Then screw nut back on bolt to avoid any damage to threads.
18. Remove band pin from lower loop of band and pull band from around drum care to be taken not to bend the band.

B. REMOVAL OF FINAL DRIVE PINION:

1. Remove Brakes. Refer to Topic 105-A.
2. Remove 8 capscrews which hold the brake drum to the driven hub. Now the drum can be pushed away from the driven hub.

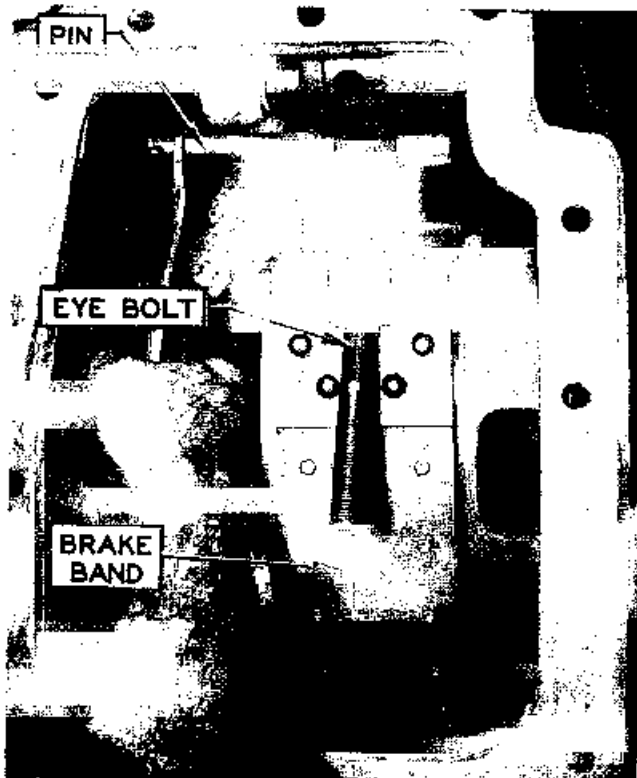

FIG. 4

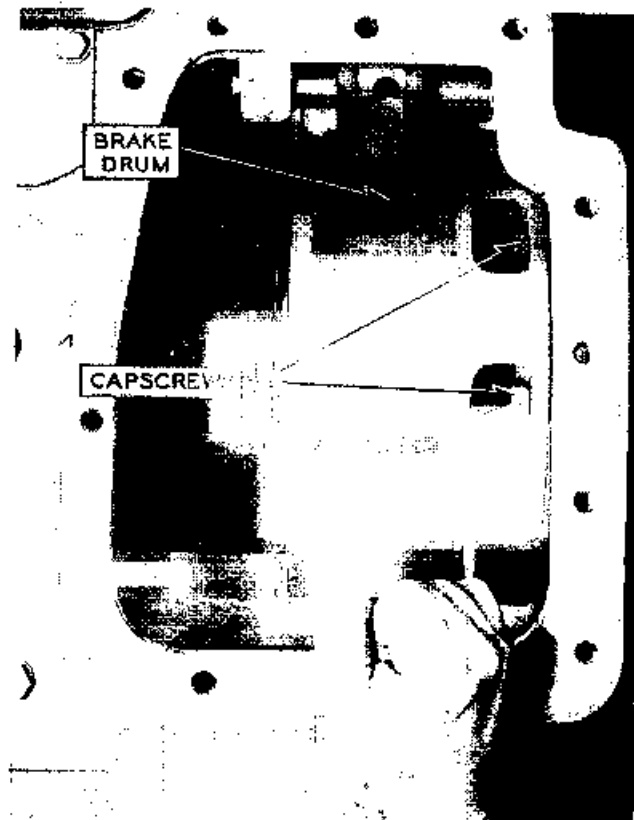

FIG. 5

3. Remove axle end covers and sprocket guards.

4. Remove covers from outer end of pinion shaft by taking out 4 capscrews in each.
NOTE: PULL PINIONS ON EACH SIDE USING SPECIAL PINION PULLER (Prior to HD 7-1132)
5. Screw adapter into end of pinion shaft and tighten thoroughly.
6. Loosen pinion shaft nut and back it off 3 or 4 threads.
7. Set puller pedestal between the sprocket spokes and directly over the adapter; screw puller bolt in place.
8. Tighten up on puller nut using a 4 ft. pipe or wrench handle, then use ram and jar pinion loose from driven hub.
9. Remove nut from end of pinion shaft.
10. Finish pulling pinion shaft from case.
11. Lift driven hub from clutch compartment.

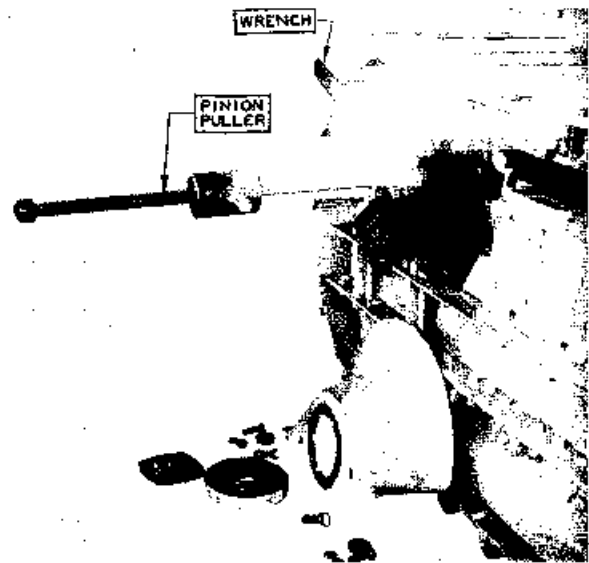

FIG. 6



FIG. 7

C. REMOVAL OF STEERING CLUTCHES:

NOTE: REMOVAL OF STEERING CLUTCH SHAFT (Prior to HD-7-1132).

1. Remove brakes. Refer to Topic 105-A.
2. Remove final drive pinion. Refer to Topic 105-B.
3. Straighten lockwashers at each end of steering clutch shaft and remove nuts with special socket.
4. Push clutch shaft either way far enough to permit one clutch to be lifted out. Push shaft in opposite direction until the other clutch can be lifted out. The spacers between the clutch hub and bevel gear hub will drop into the case when the clutches are removed from the compartments. Be sure they are in place when reinstalling clutches.

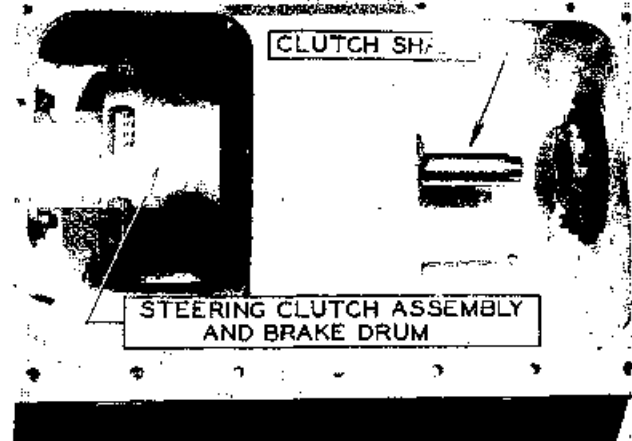

FIG. 8

NOTE: Removal of Steering Clutch Shaft above Serial No. HD 7 1132. On the second type steering clutch shaft, it is necessary to remove only one drive pinion to remove the steering clutches.

5. Pull the pinion opposite the clutch to be removed if only one clutch is to be taken out.
6. Cut lock wire on adjustable spacer nut lock screw and turn screw out far enough to clear spline in the clutch shaft.

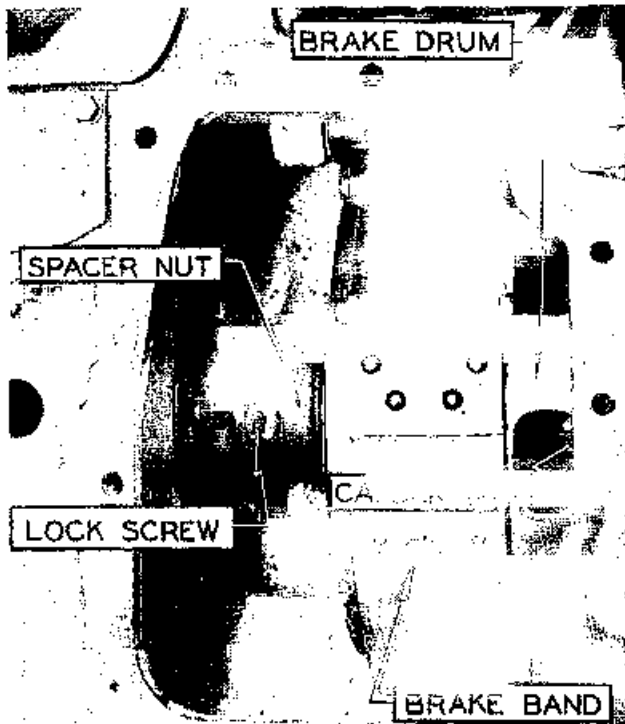

FIG. 9



FIG. 10

7. Screw one spacer nut clockwise to loosen steering clutches on shaft and slide the clutch toward the center.
8. Remove split lock rings from ends of shaft.
9. Place pinion puller in end of clutch shaft and pull shaft from clutch assembly.
10. Clutches can now be lifted from compartment.



FIG. 11

D. DISMANTLE STEERING CLUTCH:

1. Remove drum from clutch assembly taking care not to bend clutch disc teeth.

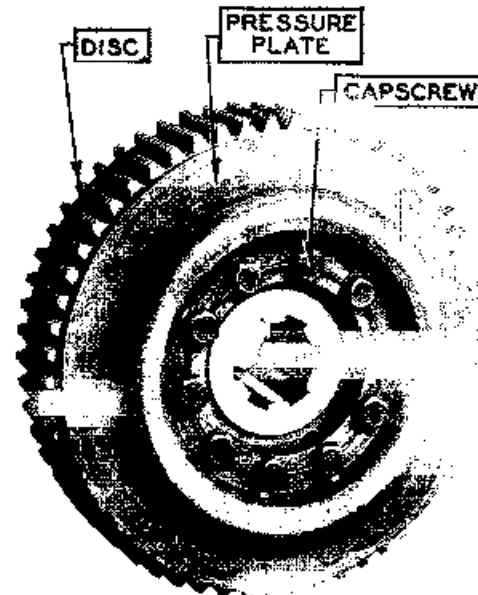

FIG. 12

2. Remove lockwire and unscrew 3 of the 10 capscrews. Fig. 13. Install in these holes 3 1/2" x 6" studs which have 1" N.F. thread on one end and 2 1/2" N.C. thread on the other end. Install the end with 1" thread in the shifter plate.
3. Install nuts on studs and tighten down against pressure plate.
4. Remove remaining capscrews; loosen the stud nuts evenly until all tension is taken off the clutch springs.

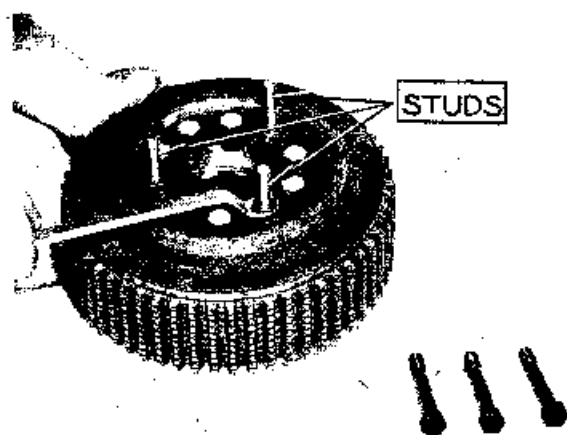

FIG. 13

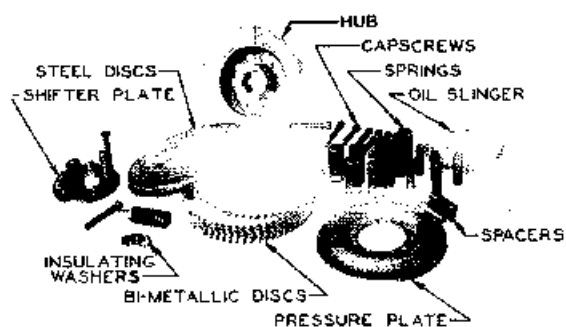

FIG. 14

5. The pressure plate, discs, springs, etc., can now be removed.

E. INSPECTION OF STEERING CLUTCH AND BEVELED GEAR HUB PARTS:

When the clutches have been removed and dismantled inspect the following items:

1. **BI-METALLIC FRICTION DISCS:** These discs are made of steel centers with bi-metallic material bonded to the steel. Thickness when new is approx. $\frac{3}{8}$ ". Inspect discs for wear and metal flaking. If overall thickness of disc is less than $\frac{1}{8}$ ", or if the metal has flaked at any point a new disc should be installed.
2. **HYCO FRICTION DISCS:** These discs are made of steel centers with wire mesh woven lining, bonded to the steel. Thickness when new is approx. $\frac{1}{8}$ ". Inspect discs for wear and material coming loose. If overall thickness of the disc is less than $\frac{1}{8}$ " or if the material has come loose at any point a new disc must be installed.
3. **RAYBESTOS FRICTION DISCS:** These discs are made of a solid piece, wire mesh and molded material. The overall thickness when new is approx. $\frac{1}{8}$ ". Inspect discs for wear, condition of teeth and oil saturation. If overall thickness of disc is less than $\frac{1}{8}$ ", or if they have been run

any length of time being oil soaked, new discs must be installed.

4. **BRAKE DRUMS:** Clean thoroughly and inspect. If drums are scored or grooved on the outer surface they can be chucked in a lathe and turned down. In doing this do not take off more than $\frac{1}{16}$ " of material, and extend the cut only to the ventilating holes. To remove any material from between the ventilating holes will materially weaken the drum.
5. **BEVEL GEAR HUB SEALS (First Type).** Inspect for proper adjustment and serviceable condition. If packing leaks, tighten adjusting nuts only enough to stop leak. If packing is worn out, adjusting nuts will screw in all the way without stopping leaks; new packing must be installed.
6. **BEVEL GEAR HUB SEALS: (Second Type).** The second type is a raw hide spring loaded seal. This seal cannot be adjusted, and if it leaks, new seals must be installed. Before new seals are installed, the bevel gear bearing adjustment must be inspected, if the adjustment is incorrect see Topic 102-H for bevel gear bearing adjustments.
7. **BEVEL GEAR BEARINGS:** Inspect for loose bearings by observing play in clutch shaft. When doing this be sure the hub packing is loosened or removed so that it does not prevent the detection of any play that may be present in the bearings.
8. **CLUTCH SPRINGS:** Inspect tension of spring by measuring its "free height" that is, its height when standing upright without anything compressing it. If this length is $3\frac{1}{4}$ " or greater the spring can be re-used. If it is less than $3\frac{1}{4}$ " it is an indication that the spring has lost its tension and new springs should be installed.

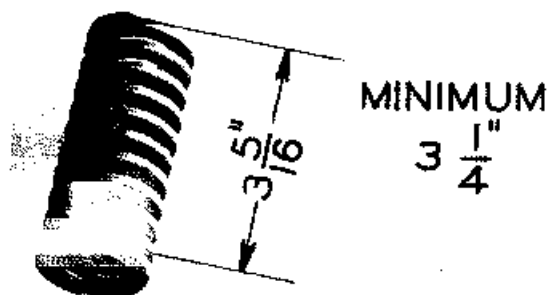

FIG. 15

9. **CLUTCH THROWOUT BEARINGS:** Inspect for wear or lack of lubrication.

Install new bearings if necessary.

10. **CLUTCH SHAFT:** Inspect splines for burrs. Be sure nuts will start on threads freely.

F. ASSEMBLY OF STEERING CLUTCH:

1. Place steering clutch hub on bench or some flat surface with spring holes up. Figure 16.

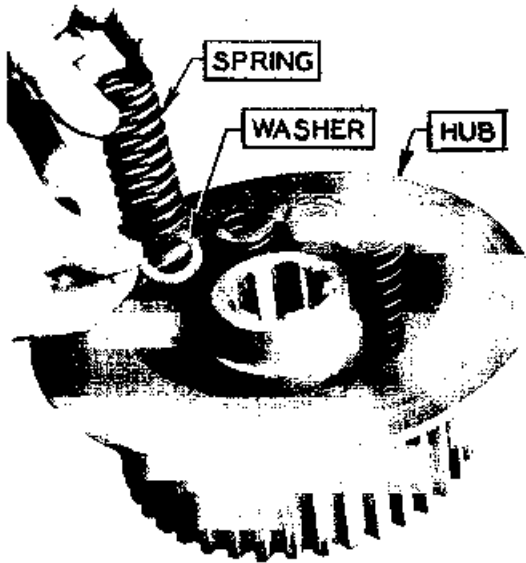

FIG. 16

2. Place an insulating washer in each hole. Make sure the washers lie flat in the bottom of the hole.
3. Place a spring in each hole. Figure 16.
4. Install oil slinger on shifter plate and set shifter plate down on springs with flat surface up. Figure 17.

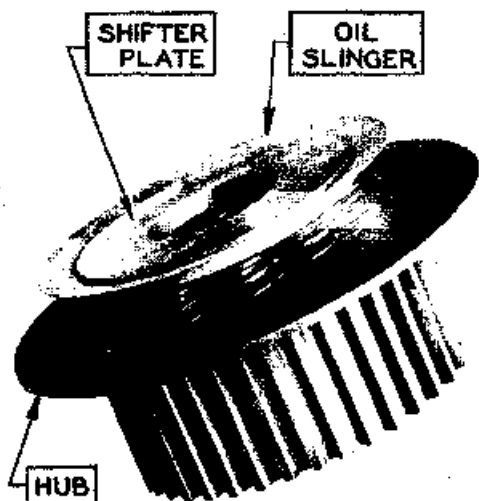

FIG. 17

5. Hold shifter plate firmly in place and turn hub assembly so that shifter plate is now on bench. Figure 18.
6. Place a spacer in each hole in hub

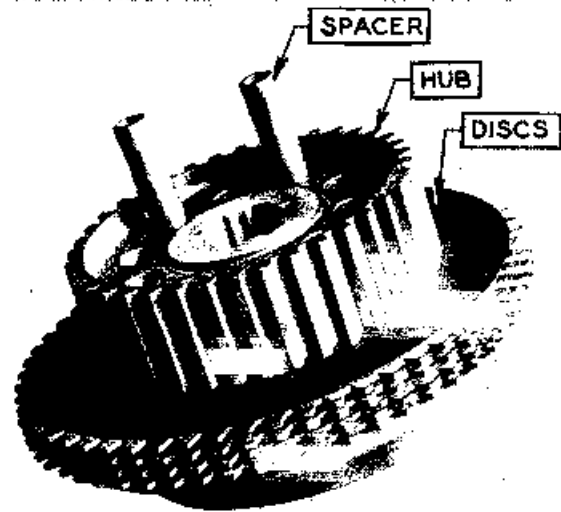

FIG. 18

through center of springs. Figure 18.

7. Stack discs alternately on hub beginning with a friction disc. Figure 18.

NOTE: Any friction disc that can be used again should be stacked on the hub first and the new discs toward the top. (See inspection of steering clutches. Stack discs on hub until stack height is approximately $3\frac{1}{8}$ ".)

8. Place pressure plate in place and screw 3 studs into the shifter plate as shown.
9. Line up teeth on clutch discs so brake drum will slide up and down on discs freely.

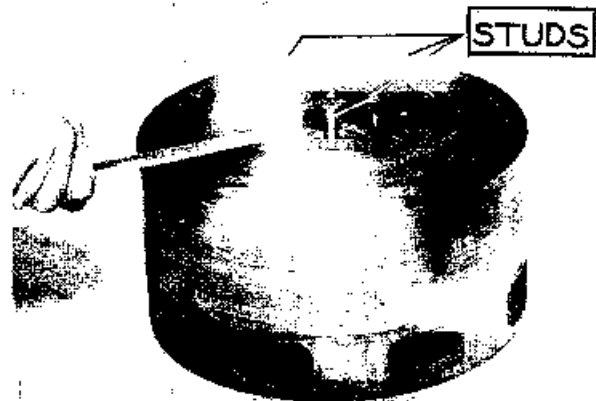

FIG. 19

10. Run nuts down on studs forcing pressure plate up as far as it will go. Now it is completely compressed. Before the bolts are installed, turn the clutch assembly up on edge and check the distance at hub and shifter plate as shown. If the measurements are within the limits, lay the clutch back, with shifter plate down. If the measurements is not within the limits and the shifter plate extends out too far, extra steel disc should be added.

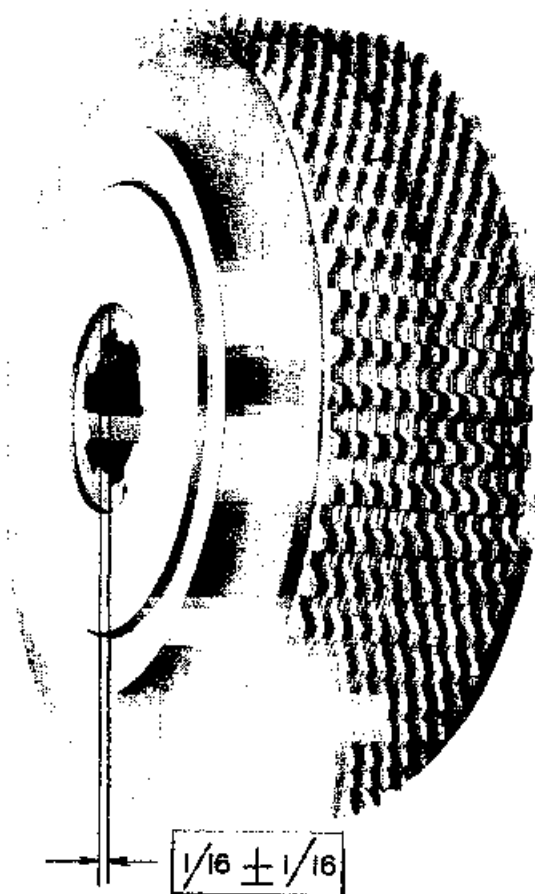

FIG. 20

If the shifter plate is in too far, remove a steel disc. In this case, all discs should be removed from hub, and reassemble with two friction discs together on the bottom of the stack. Complete stack height by alternating discs so there will be a steel disc on top when assembled.

11. Install 8 of the capscrews and tighten. Remove the 3 assembling studs and replace the remaining 3 capscrews and tighten securely, lining up the holes in bolt heads and place wire as shown.
12. Repeat the above operations for the other clutch.

G. INSTALLATION OF STEERING CLUTCHES (First type Clutch Shaft prior to "HD 7" #1132)

1. Place steering clutch assembly in brake drum and lower into clutch compartment.
2. Install clutch shaft in bevel gear hub from opposite side, and push through far enough to place spacer on end of shaft.
3. Lift clutch assembly up to align the hole in the clutch hub and the hole in the bevel gear hub. Push shaft through clutch hub, taking care not to damage the threads on the end of the clutch

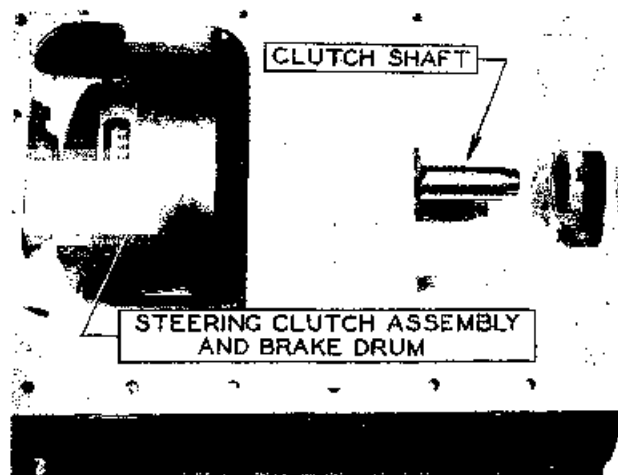

FIG. 21

shaft. The clutch may have to be rotated slightly to get the splines on the shaft to line up with the splined steering clutch hub.

4. Push shaft through until the other clutch can be lowered into the opposite compartment. Place spacer and clutch on shaft.
5. Install thick washer, lockwasher, (with cup part out) and nut on one end of shaft. Run nut on tight.
6. Install washer, lockwasher, and nut on the other end. Draw the latter nut up tight with the special wrench and bend the lockwashers over nut.

H. INSTALLATION OF STEERING CLUTCHES (Second Type Clutch Shaft, Effective "HD 7" #1132)

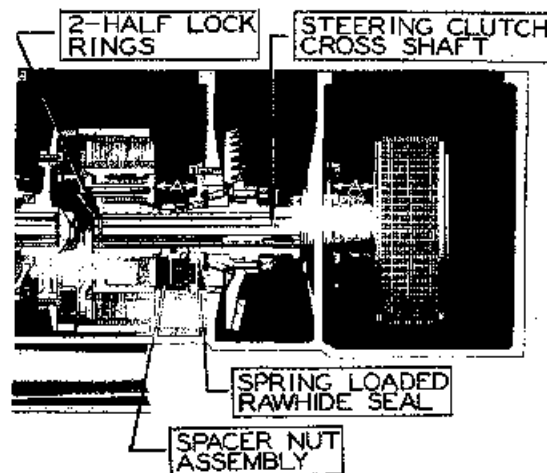

FIG. 22

1. Install clutch shaft through final drive housing and on through bevel gear hub far enough to slide adjustable spacer on spline.
2. Place steering clutch assembly in compartment and align splines of shaft with those in the clutch hub.

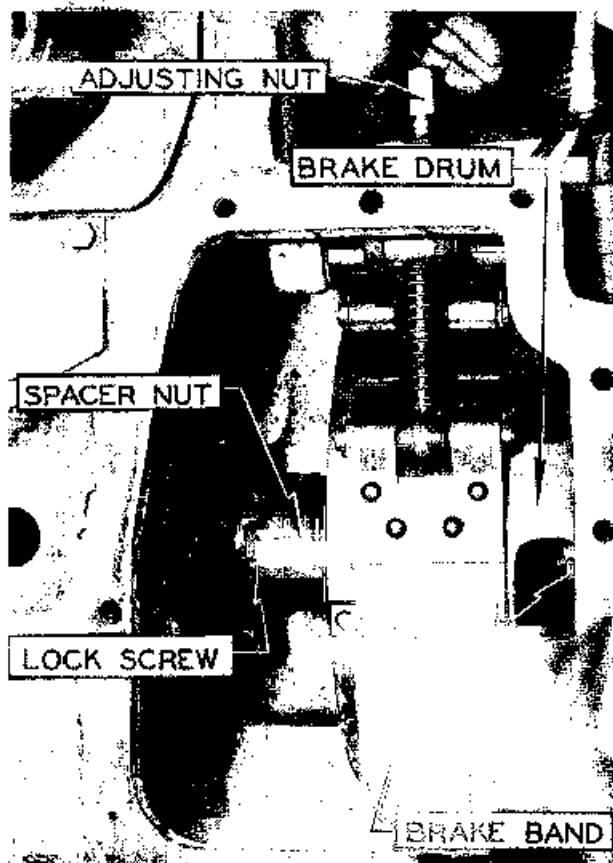

FIG. 23

3. Push shaft through clutch hub far enough to place spacer nut on other end of the shaft.
4. Place second clutch in compartment and push shaft through the clutch hub.
5. Install split lock rings on outer ends of clutch shaft and slide the clutch assembly against the lock rings making certain that the lock rings are in the counterbore of the clutch hub.
6. Tighten the adjustable spacer nut on each side equally and securely. Tighten the lock capscrew in the spacer nut, making certain that the capscrew seats between the splines in the clutch shaft, and lock with a wire.

I. INSTALLATION OF FINAL DRIVE PINIONS:

1. Install keys in driven hub; peen over edges of slots in the hub so the keys will not fall out; place hub in clutch compartment.
2. Remove bearing from outer end of pinion; shove pinion through inner bearing with key way on both top and bottom far enough to place Duprene seal over end of shaft.
3. Lift hub and align keys with keyways in the pinion shaft, push driven hub into rawhide seal and hold firmly by placing a bar on each side of the hub and prying it toward the pinion.

4. With the aid of the pinion puller adaptor, screw puller and ram assembled to pinion, drive the pinion in until the lockwasher and nut can be started on the shaft.
5. Drive pinion shaft through hub, holding against driven hub with bars. Place lock washer and nut on shaft and tighten with the aid of the ram, drive in on pinion. Give the nut a final pull, bend the lockwashers over in two places on hub and two on nut, and remove pinion puller parts.
6. Install bearing on outer end of pinion with shielded side toward gear. Install cover and gasket over end of pinion shaft.
7. Replace sprocket shield and axle end cap.

J. INSTALLATION OF BRAKES:

1. Install brake band taking care that the bands fit drum properly.
2. Install pin and cotter keys in lower part of band.
3. Install spring on adjusting bolt, adjusting bolt in swivel pin and install adjusting nut.
4. Install adjusting screw and jam nut in the bottom of transmission case to hold the brake band in its proper place. Run the screw up against the band, forcing the band against the drum just snug with fingers, then back off $\frac{1}{2}$ turn and

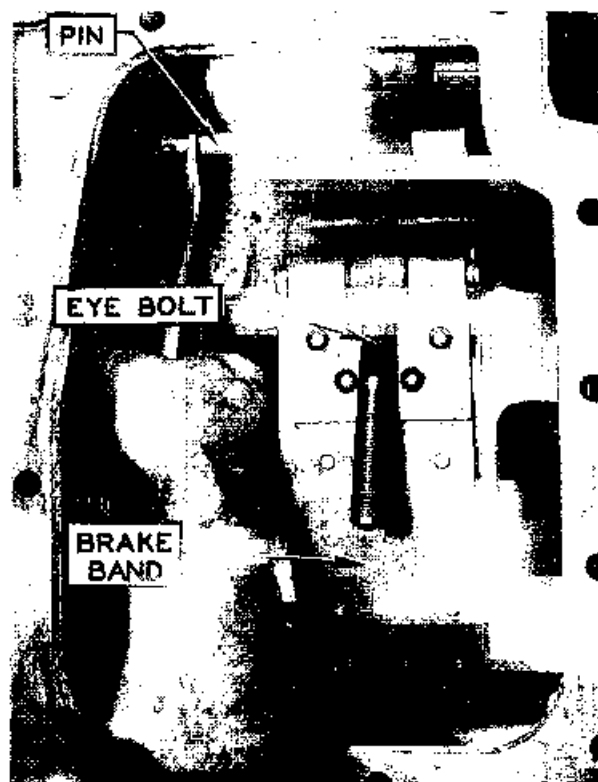
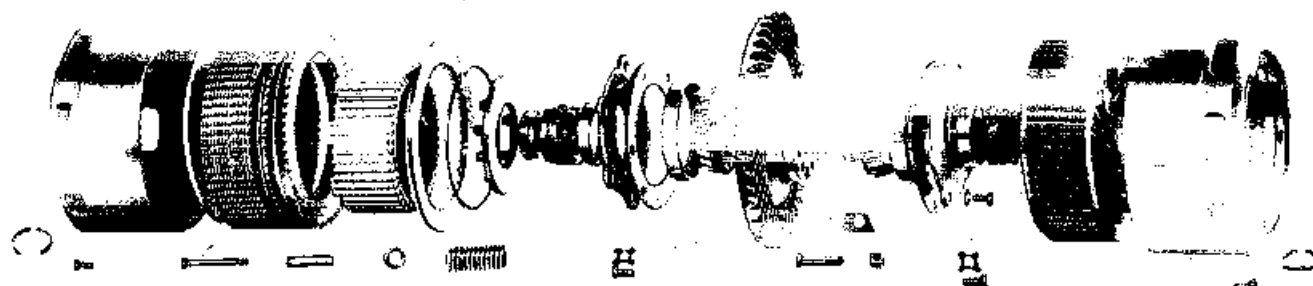

FIG. 24

- lock jam nut. This adjustment screw holds the brake band up in its proper location.
5. Install brake spring in brake lever.
 6. Install equalizer bar in bottom of transmission case.
 7. Install throwout fork assembly, making sure it seats in the equalizer.
 8. Install steering clutch cover and grease

9. Adjust brakes. Refer to brake adjustment, Topic 57-A, and install brake adjustment cover.
10. Adjust steering clutches; refer to steering clutch adjustment, Topic 55-A, and install top cover.
11. Install remaining parts that were removed.

106 -- "HD 10" Steering Clutches and Brakes



EXPLODED VIEW OF STEERING CLUTCH AND BEVEL GEAR

FIG. 1

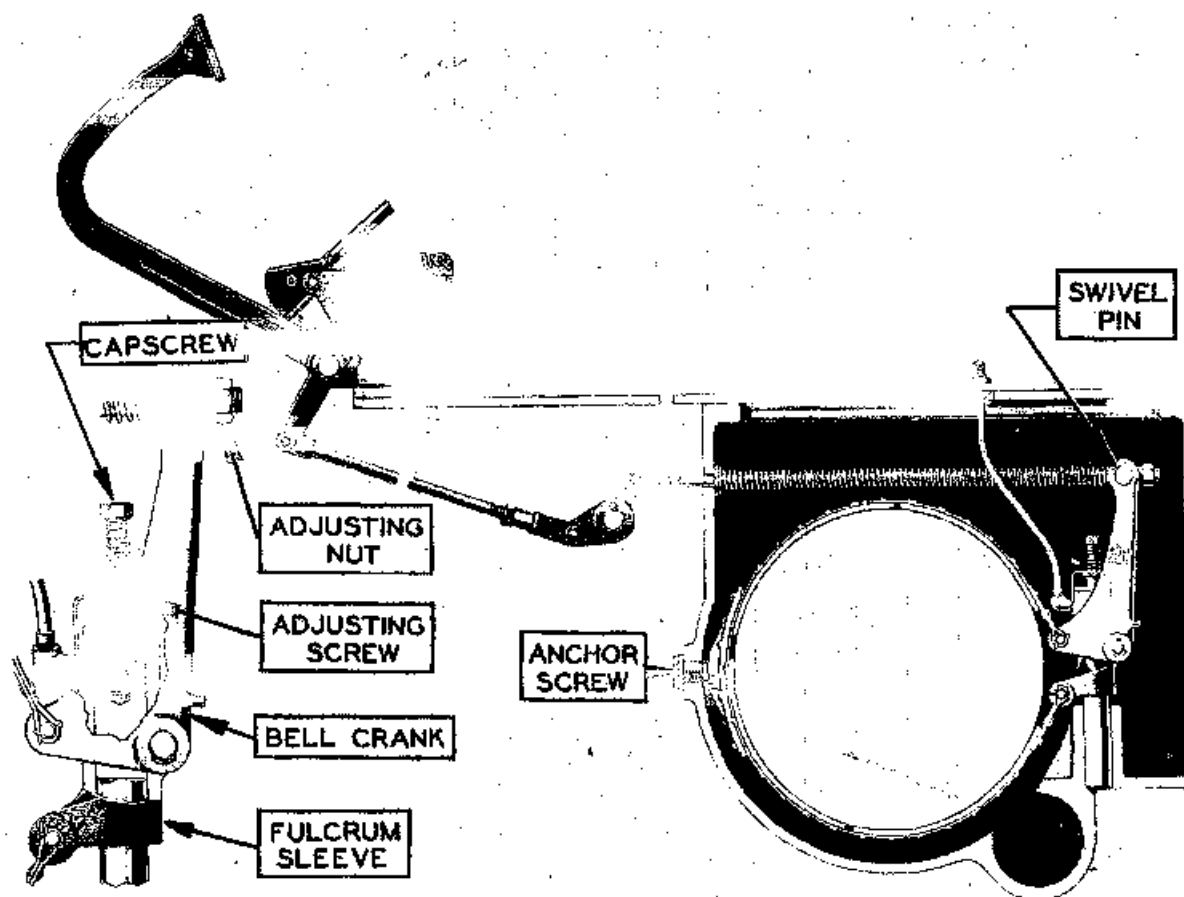

FIG. 2