



1. DESCRIPTION

Steering clutches of the multiple dry disc, spring-loaded type are located, one in each side of the drive bevel gear compartment, at the rear of the main frame. The steering clutches are controlled manually by levers directly in front of the operator. Each clutch consists of steel drive discs with teeth on the outside and fiber or sintered bronze friction discs with teeth on the inside. The discs are held compressed by a heavy coil spring. A release fork connected to the steering levers in front of the operator compresses the coil spring to allow the friction discs to rotate between the driving discs when the steering clutch is disengaged. The release collar is equipped with a ball type thrust bearing.

The function of the steering clutches is to disengage the flow of power to one track for the

purpose of steering the tractor. When one track is disengaged, the other track will continue traveling and the tractor will turn on the disengaged track.

A steering brake is provided for each steering clutch. Its purpose is to stop the clutch drum from rotating after the steering clutch has been disengaged. This locks one track and forms a pivot point for short turns. Brakes also may be used for parking purposes. Pedals for each brake are adjustable to suit the operator. Each pedal may be locked in holding position. The brakes are simple and very accessible and are of external contracting type, contracting on the steering clutch drums. Brake bands may be relined after removing them from convenient holes in the bottom of the main frame.

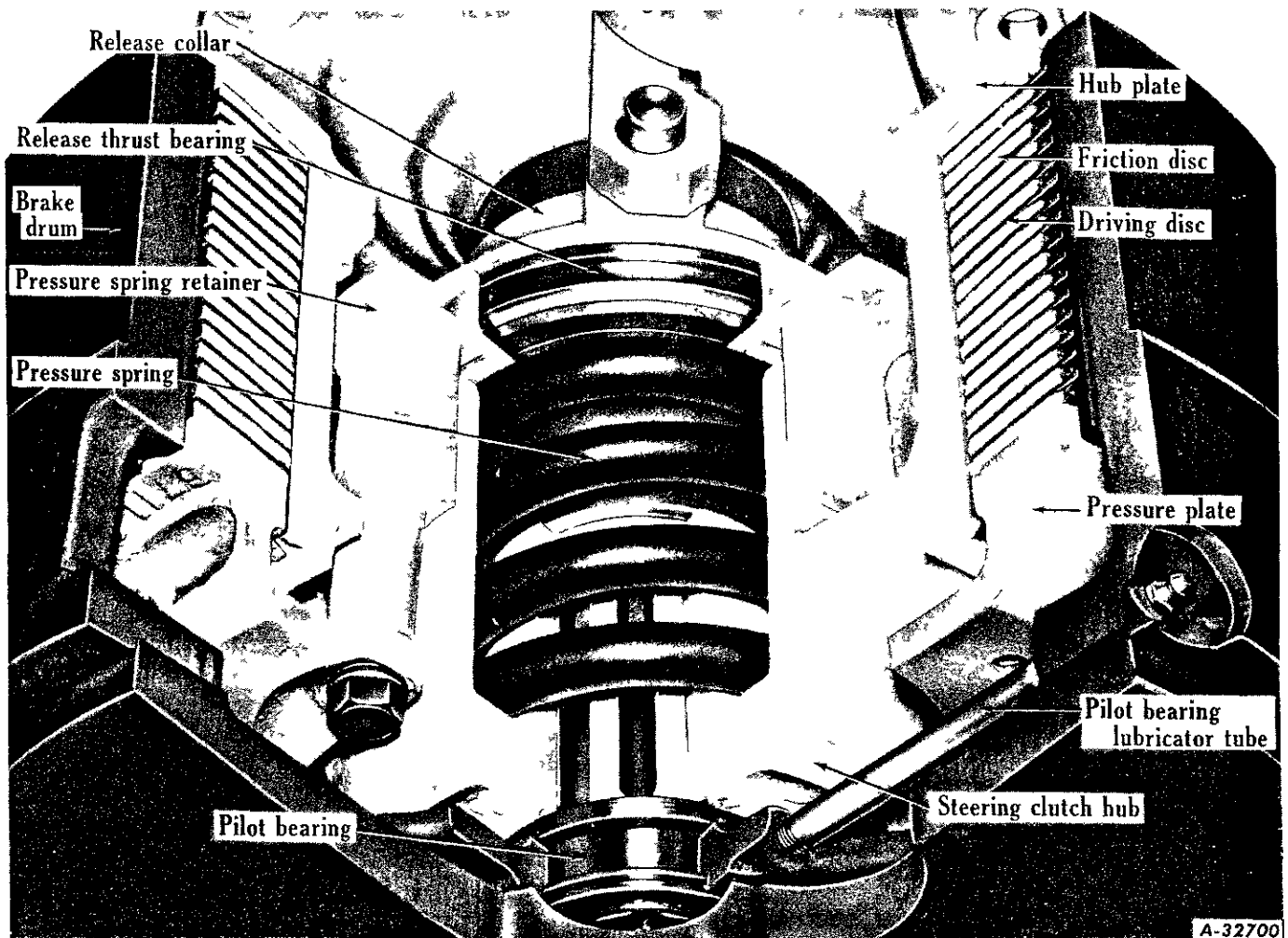

Illust. 1 - Cutaway View of Steering Clutch.



2. SPECIFICATIONS

STEERING CLUTCHES

Type Multiple dry disc, spring loaded
 Number 2
 Location Each side of bevel gear, on sprocket drive pinion shaft.
 Nominal diameter 15 in.

Number of driving discs:

14 and 15 series (.087-.099 in. thick) . 12
 (.120-.130 in. thick) . 11
 18 and 20 series (.087-.099 in. thick) . 17
 (.120-.130 in. thick) . 15

Number of friction discs:

14 and 15 series (fiber) 13
 (bronze) 12
 18 and 20 series (fiber) 18
 (bronze) 16

Maximum warp before replacing discs005 in.

Pressure spring

Free length,
 approx. (14-14A) 6-9/16 ± 1/8 in.
 (141-142-15(150) 7-1/4 in.
 (18-18A) 8-1/16 in.
 (181-182-20(200) 8-9/64 in.

Test length

at 2250 lb. (14-14A) 4-5/16 in.
 at 2745 lb. (-5+15%) (141-142-15(150) 4-5/16 in.
 at 2575 lb. (-5+15%) (18-18A) 5 in.
 at 3775 lb. (-5+15%) (181-182-20(200) 5 in.

Control Mechanism

Type of system Mechanical
 How actuated Hand levers

STEERING BRAKES

Type External contracting bands
 Location On each steering clutch drum
 Brake drum diameter 17 in.
 Maximum stock removal for refinishing drum (standard lining) . . .015 in.
 Width of lining . . (14 and 15 Series) 3 in.
 (18 and 20 Series) 4 in.

Thickness of lining:

Not floating pivot type 1/4 in.
 Floating pivot type 3/8 in.

Brake lining to drum clearance 1/64 in.

Brake pedal free movement 3 in.

Control mechanism:

Type of system Mechanical
 How actuated Individual pedals

Clearance between steering clutch drum and band

opposite set screw 1/64 in.

Steering brake band release spring - (Not floating pivot type) -

Free length 4-5/8 in.
 Test length 2-1/2 in.
 Test load 18-22 lb.

(Floating pivot type) -

Free length 4-57/64 in.
 Test length 3-1/2 in.
 Test load 40 lb.

Steering brake band anchor spring - (Not floating pivot type) -

Free length 2-1/16 in.
 Test length 1-1/2 in.
 Test load 18-22 lb.

(Floating pivot type) -

Free length 3-1/4 in.
 Test length 2-1/2 in.
 Test load 35 lb.



- Steering brake rod return spring -
 (Not floating pivot type) -
 Free length 10-5/16 in.
 Test length 14-3/16 in.
 Test load 53 to 65 lb.
- (Floating pivot type) -
 Free length 6-1/4 in.
 Test length 7-3/4 in.
 Test load 92-1/4 to 112-3/4 lb.

- Brake locking pawl spring -
 (Floating pivot type) -
 Free length 3-11/32 in.
 Test length 3-3/4 in.
 Test load 31-1/2 to 35 lb.

SPECIAL TORQUES * IN Foot Pounds

- Steering Clutch Pilot Bearing
 Retaining Nut 180 - 220
- Steering Clutch Support
 Bearing Nut. 280 - 320

*All Threads Lubricated with SAE-30 Engine Oil.

3. MAINTENANCE

1. When operating the tractor in water or under very wet conditions, or under extremely dusty conditions, water or dust may enter the steering clutch compartments through the holes in the drain plugs. To avoid this, replace the drain plugs (if used) with solid pipe plugs. Re-

move the solid plugs after every 60 hours of operation to allow any accumulation of water or oil to drain out.

2. If the steering clutches start to slip, measure the free movement of the steering clutch levers. If the free movement is less than the amount given in paragraph 2, adjustment is necessary.

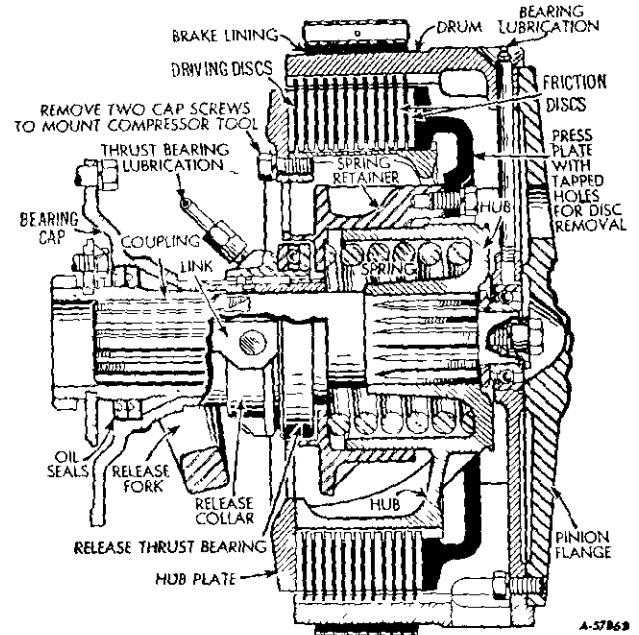

Illustr. 2 - Cross Section of Steering Clutch.

4. CHECKING MECHANICAL PROBLEMS

PROBABLE CAUSE	REMEDY
Tractor Does Not Move	
1. Steering brakes locked	Release the steering brake pedals from the latching pawls.
2. Engine clutch faulty	Refer to "ENGINE CLUTCH," Section 5.
3. Transmission faulty	Refer to "TRANSMISSION AND BEVEL GEAR" Section 6 or 6A.
4. Steering clutches slip - incorrect adjustment	Adjust to correct specifications or remove and repair steering clutches.
Tractor Moves with Brakes Locked (Brakes do not hold)	
1. Brake lining worn	Install new lining.
2. Improper brake adjustment	Adjust steering brakes.

continued on next page



4. CHECKING MECHANICAL PROBLEMS - Continued

PROBABLE CAUSE

REMEDY

Tractor Moves with Brakes Locked - Continued
(Brakes do not hold)

- | | |
|----------------------------------|--|
| 3. Oil on brake lining | Wash brake linings, or if badly oil-soaked install new lining. |
| 4. Brake band broken | Install new brake band. |
| 5. Broken linkage | Install new linkage parts. |

Tractor Does Not Turn
(Steering clutch does not disengage)

- | | |
|--|---|
| 1. Improper operation of steering clutch lever | Pull steering clutch hand lever all the way back. |
| 2. Improper adjustment | Properly adjust controls. |
| 3. Steering clutch faulty | Remove and repair steering clutches. |
| 4. Faulty steering clutch hydraulic system | Refer to paragraph 18. |

Tractor Will Not Make Short (Pivot) Turn

- | | |
|---|---|
| 1. Steering clutch does not disengage | See problem "Tractor Does Not Turn." |
| 2. Steering brake will not hold | Adjust brake and controls, or replace brake if necessary. |

Tractor Moves but Creeps to One Side

- | | |
|--|--|
| 1. Track or track frame faulty | Inspect track frames for parallel alignment. Correct or replace parts as necessary. |
| 2. Steering brake drags | Remove steering brake inspection cover and hand feel the steering brake band. If band is hot, brake is dragging. Adjust brake. |
| 3. Steering clutch slips | Adjust steering clutch, and if clutch is faulty, remove and repair. |

Tractor Loses Pulling Power

- | | |
|-------------------------------------|---|
| 1. Steering brakes drag | Remove inspection cover and hand feel the steering brake bands. If bands are hot, brakes are dragging. Adjust brakes. |
| 2. Steering clutches slip | Adjust steering clutches. If clutches are faulty, remove and repair. |
| 3. Engine clutch slips | Refer to "ENGINE CLUTCH," Section 5. |

Steering Clutches Overheat

- | | |
|--|---|
| 1. Improper use of steering brakes | Steering brakes should never be applied unless steering clutches are completely disengaged. |
| 2. Steering brakes drag | Remove inspection cover and hand feel the steering brake bands. If bands are hot, brakes are dragging. Adjust brakes. |
| 3. Steering clutches slip | Adjust steering clutches. If clutches are faulty, remove and repair. |



PROBABLE CAUSE

REMEDY

Steering Brakes Overheat

- | | |
|--|---|
| 1. Brakes adjusted too tight | Adjust brakes to proper clearances. |
| 2. Steering clutch does not disengage | |
| (a) Improper adjustment | Adjust steering clutch. |
| (b) Warped discs | Replace warped discs. |
| 3. Oil on brake lining | Wash or replace lining. |
| 4. Binding in brake controls. | Free controls and lubricate with light oil. |

STEERING BRAKES

5. REMOVAL

Not Floating Pivot Type

1. Unscrew the brake rod adjusting knob and remove the inspection covers from the bottom and rear of the main frame. (See Illusts. 3 and 4.)

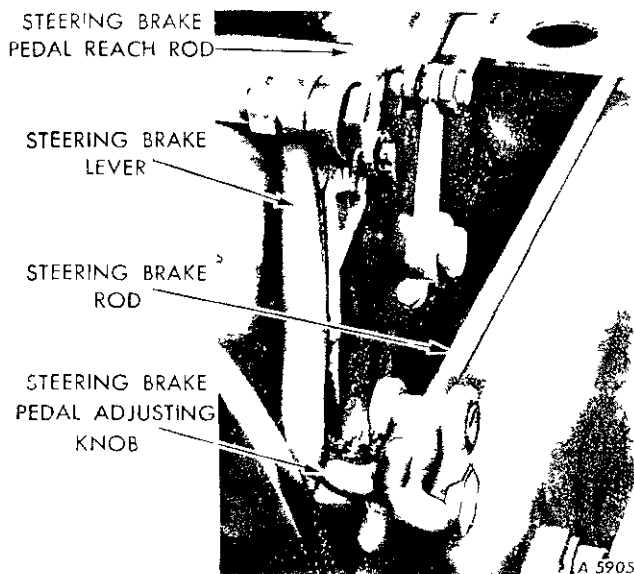

Illust. 3 - Steering Brake Pedal Adjusting Knob.

2. Back out the set screw until it is free of the brake band and unhook the anchor spring. (See Illusts. 5 and 6.) Remove the band adjusting bolt to free the brake band.

3. Remove the pin from the inner rod yoke and pivot lever and remove the pivot shaft stud from the center end of the pivot shaft. With a screwdriver work the shaft to the inside of the frame until the shaft is free.

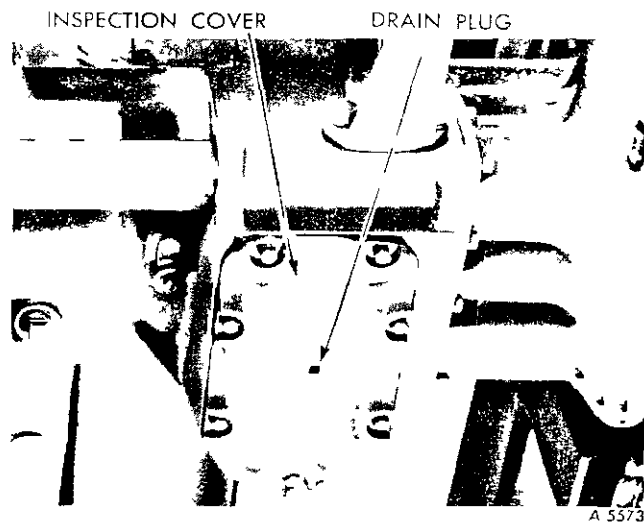

Illust. 4 - Under Side of Tractor Showing Steering Brake Inspection Cover

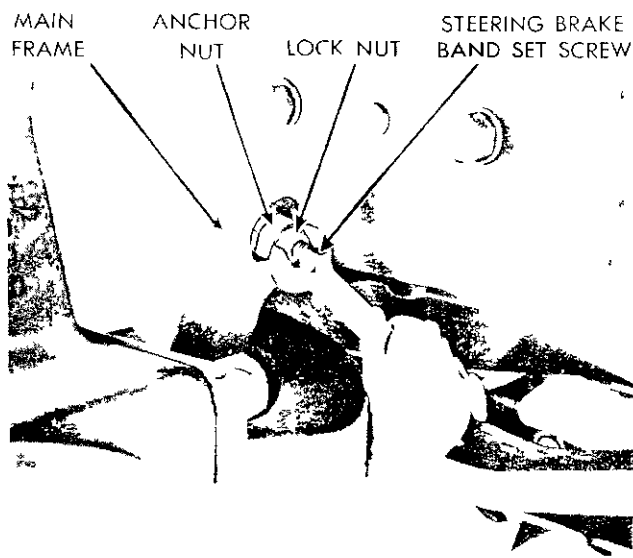

Illust. 5 - Backing Out Steering Brake Band Set Screw.

continued on next page



STEERING BRAKES

5. REMOVAL - Continued

Not Floating Pivot Type - Continued

4. Pull down on the pivot lever to slide the brake band assembly from around the brake drum and remove the pins which hold the band together and the front band to the pivot lever. (See Illust. 7.)

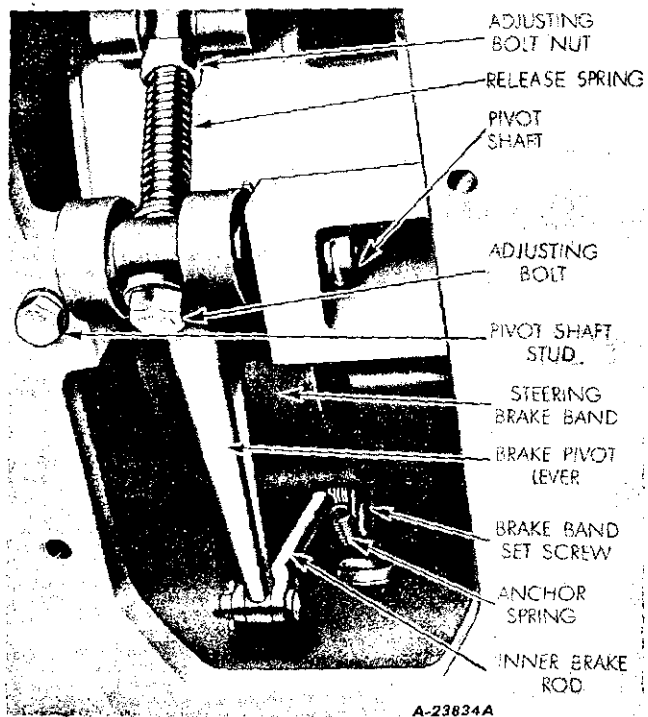

Illust. 6 - Bottom View of Steering Brake.

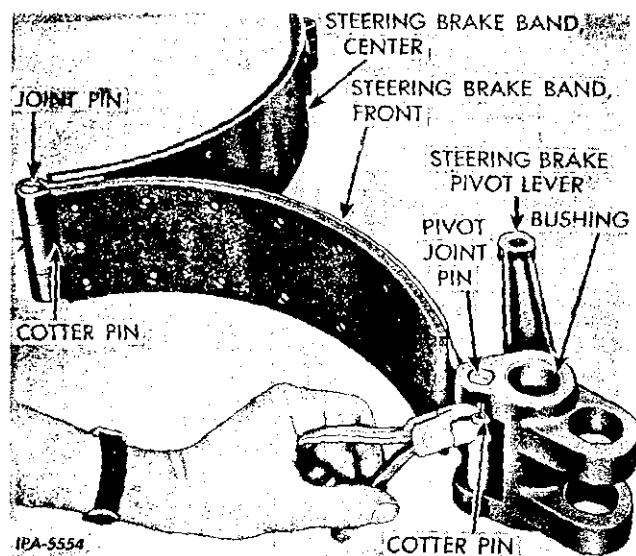

Illust. 7 - Showing Sections of Brake Bands Fastened by Joint Pins.

Floating Pivot Type

1. Remove the adjusting set screw from the rear main frame (Illust. 5).
2. Remove the inspection cover from the bottom of the rear main frame (Illust. 8).



Illust. 8 - Removing Lower Inspection Cover.

3. Remove the retainer (27, Illust. 16) securing the pivot lever pin to the pivot lever (42). If the pivot lever pin is secured with a "TRU-ARC" snap ring, remove snap ring with a "TRUARC" standard pliers, No. 2 with 90 degree tips (Illust. 9).
4. Remove the pivot lever pin (Illust. 10).
5. Remove the retaining spring or "TRUARC" snap ring (if equipped) and the joint pin that secures the rear brake band to the adjusting yoke (Illust. 11).
6. Remove the cotter pin or "TRUARC" snap ring (if equipped) and the pin that secures the pivot lever to the inner brake rod (Illust. 12).
7. Remove the four cap screws and lock washers that secure the anchor bracket to the rear main frame and remove the anchor bracket (Illust. 13).
8. Push the rear brake band up and around the brake drum to loosen the top anchor spring. Remove the spring.



STEERING BRAKES

9. Push the front brake band up and around the brake drum to loosen the lower anchor spring. Remove the spring.

10. Push the front brake band up and around the brake drum until the joint pin that secures the rear and center brake band is accessible.

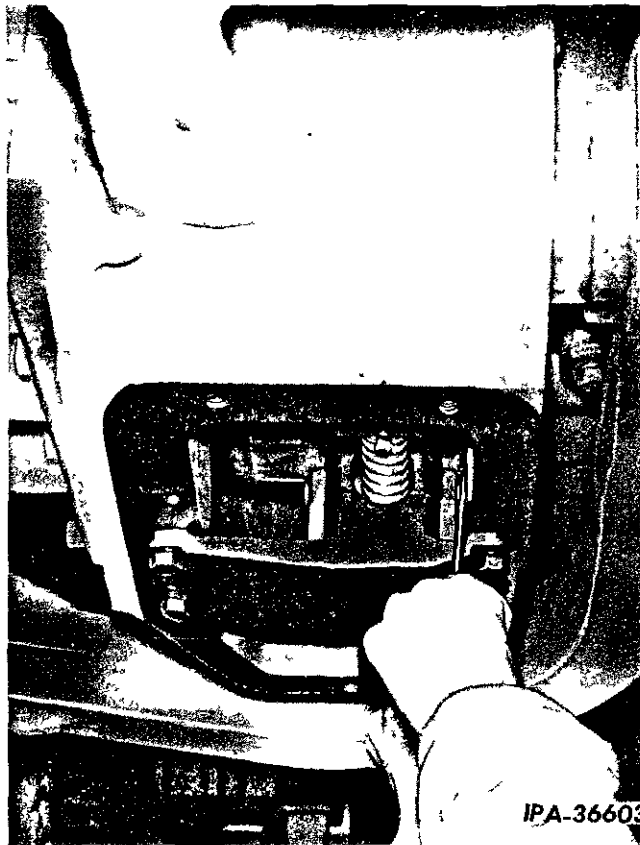

Illust. 9 - Removing Snap Ring from Pivot Lever Pin.

Remove the retaining spring or "TRUARC" snap ring (if equipped). Remove the joint pin and rear brake band (Illust. 14).

 **CAUTION:** If the brake band is equipped with a spreader, hold in place so that it does not suddenly come loose and cause injury, when removing the joint pin.

11. Pull the front and center brake bands around the front of the brake drum and out through the bottom of the rear main frame (Illust. 15).

continued on next page

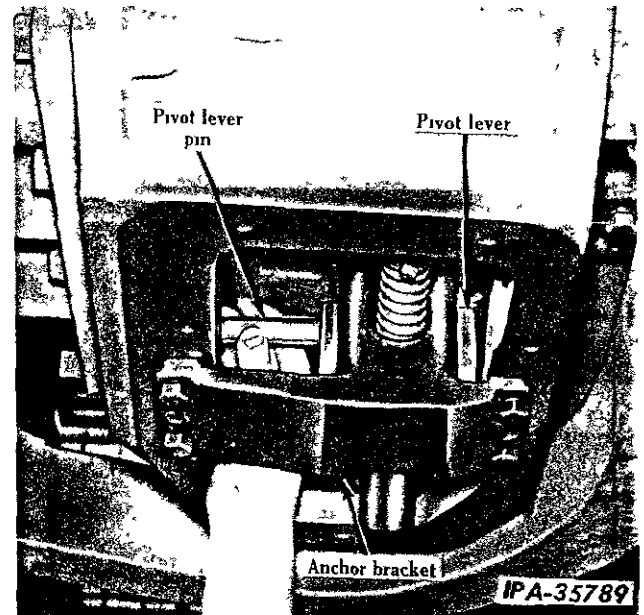

Illust. 10 - Removing Pivot Lever Pin.

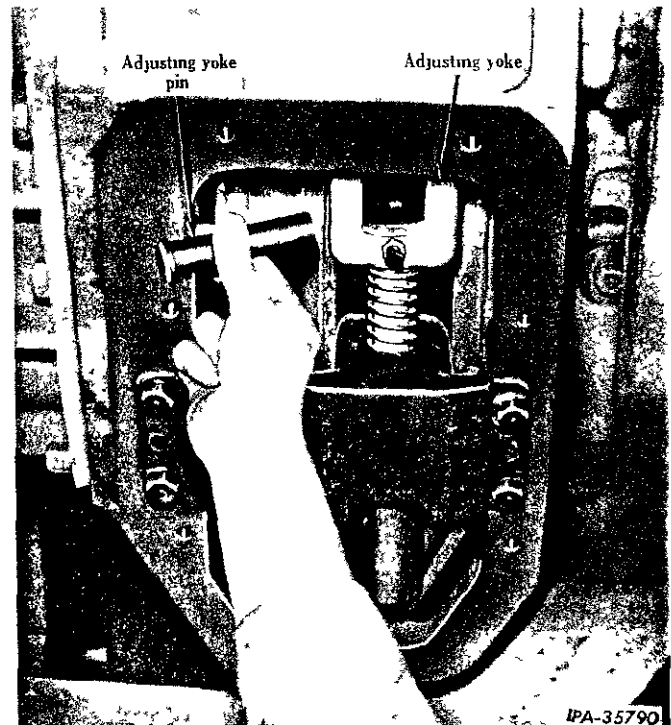

Illust. 11 - Removing Adjusting Yoke Pin.



STEERING BRAKES

5. REMOVAL - Continued

Floating Pivot Type - Continued

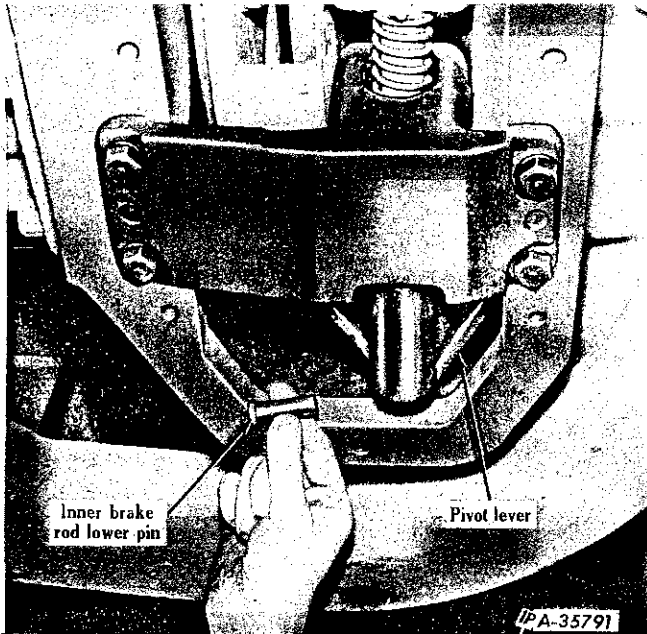

Illust. 12 - Removing Inner Brake Lower Pin.

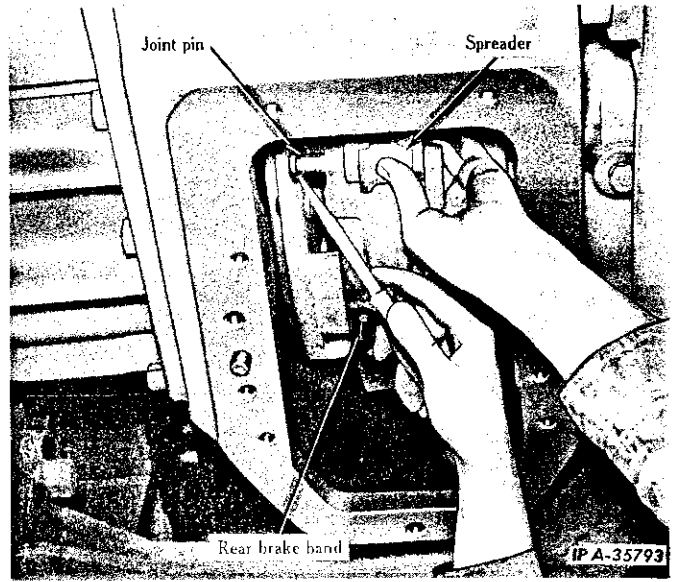

Illust. 14 - Removing Rear Brake Band Joint Pin.

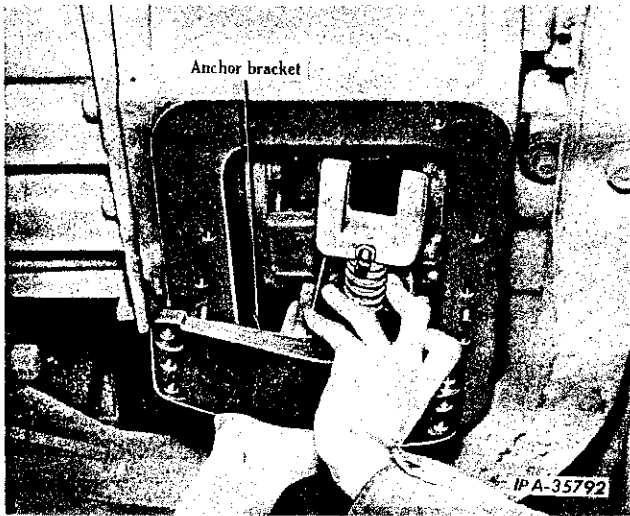

Illust. 13 - Removing Anchor Bracket.

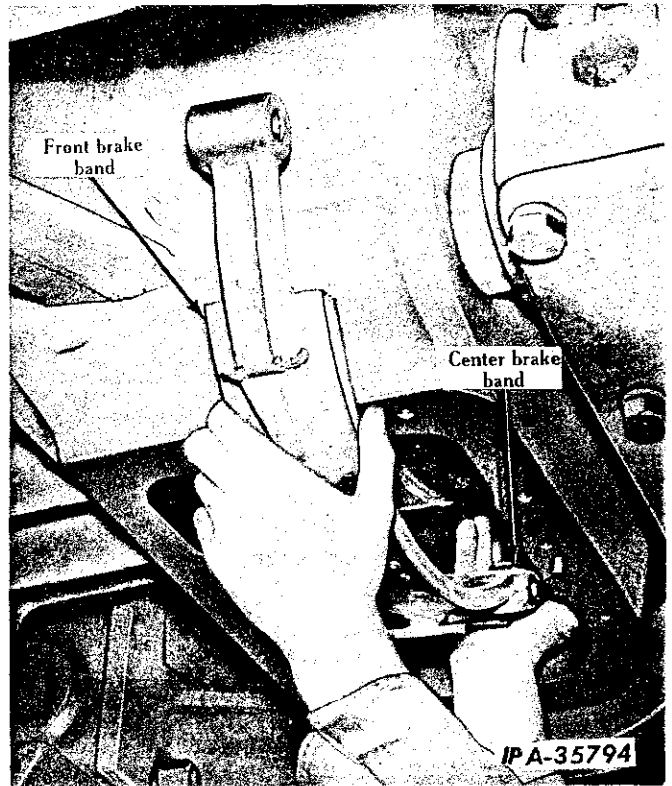

Illust. 15 - Removing Front and Center Brake Bands.

DISASSEMBLY

(Reference Numbers refer to Illust. 16)

1. Remove the retaining spring or "TRUARC" snap ring (if equipped) (32, Illust. 16) from the front and center brake band joint pin.

2. Remove the joint pin (25) from the front and center bands (23) and (29).

continued on page 10



STEERING BRAKES

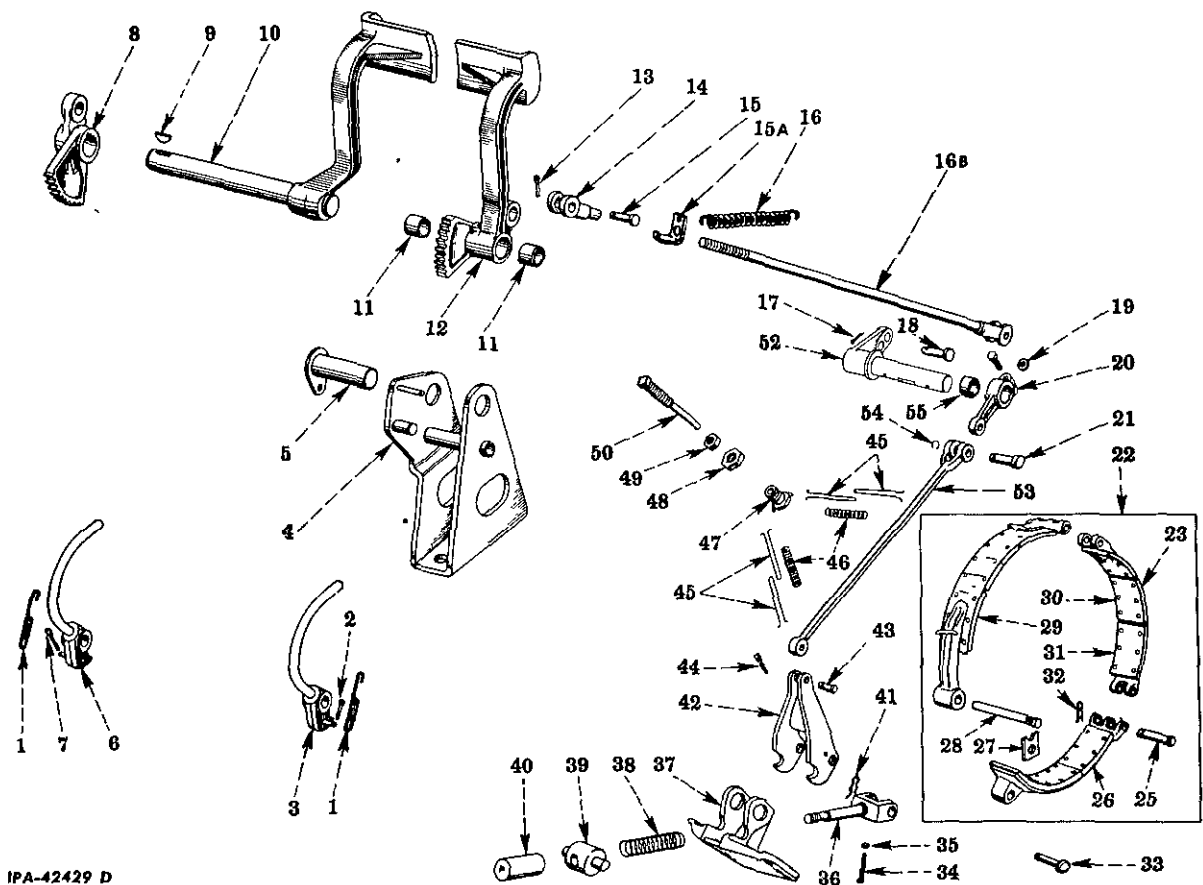

IPA-42429 D

Illust. 16 - Exploded View of Floating Pivot Type Steering Brake Assembly. (150 and 200 Series Shown, 142 and 182 Series Similar.)

1. Locking pawl spring.
2. Ratchet pawl cotter pin.
3. Ratchet pawl, L.H.
4. Pedal support, L.H.
5. Pedal shaft, L.H.
6. Ratchet pawl, R.H.
7. Ratchet pawl cotter pin.
8. Arm and ratchet, R.H.
9. Arm and ratchet key.
10. Pedal, R.H.
11. Pedal bushing, L.H.
12. Brake pedal, L.H.
13. Brake rod outer adjustable clevis end pin cotter pin.
14. Brake rod outer adjustable clevis.
15. Brake rod outer adjustable clevis end pin.
- 15A. Return spring front anchor.
16. Return spring.
- 16B. Steering brake outer rod.
17. Cotter pin.
18. Brake rod end pin.
19. Brake lever inner key.
20. Brake inner lever.
21. Brake rod inner end pin, upper.
22. Brake band, assembly.
23. Brake band, center.
25. Brake band hinge pin.
26. Brake band, rear.
27. Brake band pivot joint pin retainer, upper.
28. Brake band pivot joint pin, upper.
29. Brake band, front.
30. Brake band lining.
31. Brake band lining rivet.
32. Brake band hinge pin retaining spring.
33. Brake band adjusting clevis pin.
34. Set screw.
35. Jam nut.
36. Brake band adjusting clevis.
37. Brake anchor bracket.
38. Brake band release spring.
39. Brake pivot joint pin, lower.
40. Brake band adjusting nut.
41. Brake band adjusting clevis pin retaining spring.
42. Brake pivot lever.
43. Brake rod end pin, inner, lower.
44. Brake rod inner end pin cotter pin.
45. Brake band anchor spring hook.
46. Brake band anchor spring.
47. Brake return spring anchor.
48. Jam nut.
49. Hex nut.
50. Brake band set screw.
52. Brake lever, outer L.H.
53. Brake rod, inner.
54. Brake rod outer end pin retaining ring.
55. Brake lever dirt seal, outer.



STEERING BRAKES

5. REMOVAL - Continued

DISASSEMBLY

(Reference Numbers refer to Illust. 16)



CAUTION: Hold the spreader so that it does not suddenly come off and cause an injury or get lost.

3. Lift off the pivot lever (42) from the lower pivot.

4. Remove the adjusting nut (40) from the adjusting clevis (36).

5. Remove the lower pivot, return spring (38) and adjusting clevis (36) from the anchor bracket (37).

6. RELINING BANDS

Not Floating Type TD-14 and TD-18

1. Remove and disassemble the steering brakes as described in paragraph 5.

2. Punch out the rivets which hold the lining to the bands and remove the lining. Scrape all traces of the old lining from the bands. Wash the bands in dry-cleaning solvent. Rivet the new linings to the brake bands.

NOTE: It is recommended that when installing a new lining, only one type or make of lining be used on the tractor.

3. Assemble and install the brakes as described in paragraph 7.

Floating Pivot Type (Standard Lining)

1. Remove and disassemble the steering brakes as described in paragraph 5.

2. Punch out the rivets which hold the lining to the bands and remove the lining. Scrape the bands thoroughly and wash in cleaning solvent. Rivet the new linings to the brake bands.

NOTE: It is recommended that when installing a new lining, only one type or make of lining be used on the tractor.

3. Assemble and install the steering brakes as described in paragraph 7.

Floating Pivot Type (Undersize Brake Drum)

A service package is available to provide a 1/2-inch thick brake band lining for steering clutch brake drums that have been turned down. The original drum diameter is 17 inches. The steering brake drum should be turned down to

16-3/4 inches to accommodate the 1/2-inch thick linings. The standard linings are 3/8-inch thick.

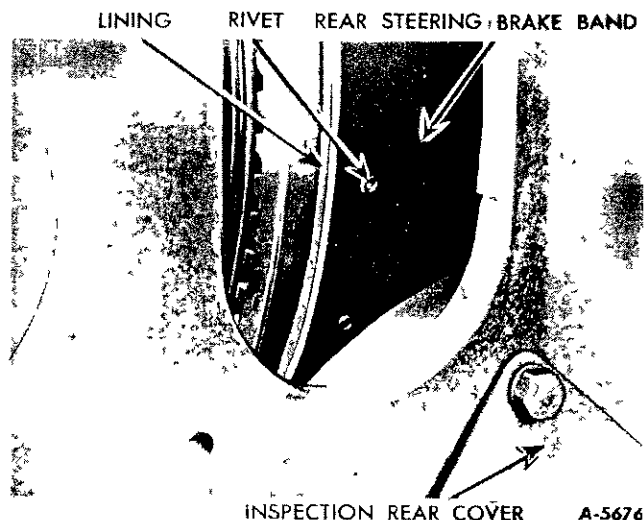

Illust. 17 - Inspection of Steering Brake.

Follow the same procedure as outlined under "Standard Lining" for relining the steering clutch brake bands.

7. ASSEMBLY AND INSTALLATION

Not Floating Pivot Type

1. Connect the brake bands with the joint pins and the front band to the pivot lever. (See Illust. 7.)

2. Slide the center and rear brake bands up and around the rear of the drum while sliding the front brake band and pivot lever up and around the front of the brake drum.

3. With a screwdriver, work the pivot shaft through the pivot lever and install the stud. Install the pin and rod yoke and lever pin.

4. Hook the anchor spring to the band and adjust the set screw so the brake band is 1/64 inch from the brake drum.

5. Lock the set screw. (See Illust. 5.) Install the band adjusting bolt; screw it in until there is 1/64 inch clearance between the band and the drum all the way around. Lock the bolt with the nut and adjust the brake band as described in paragraph 8. Install the inspection cover on the bottom of the main frame.



STEERING BRAKES

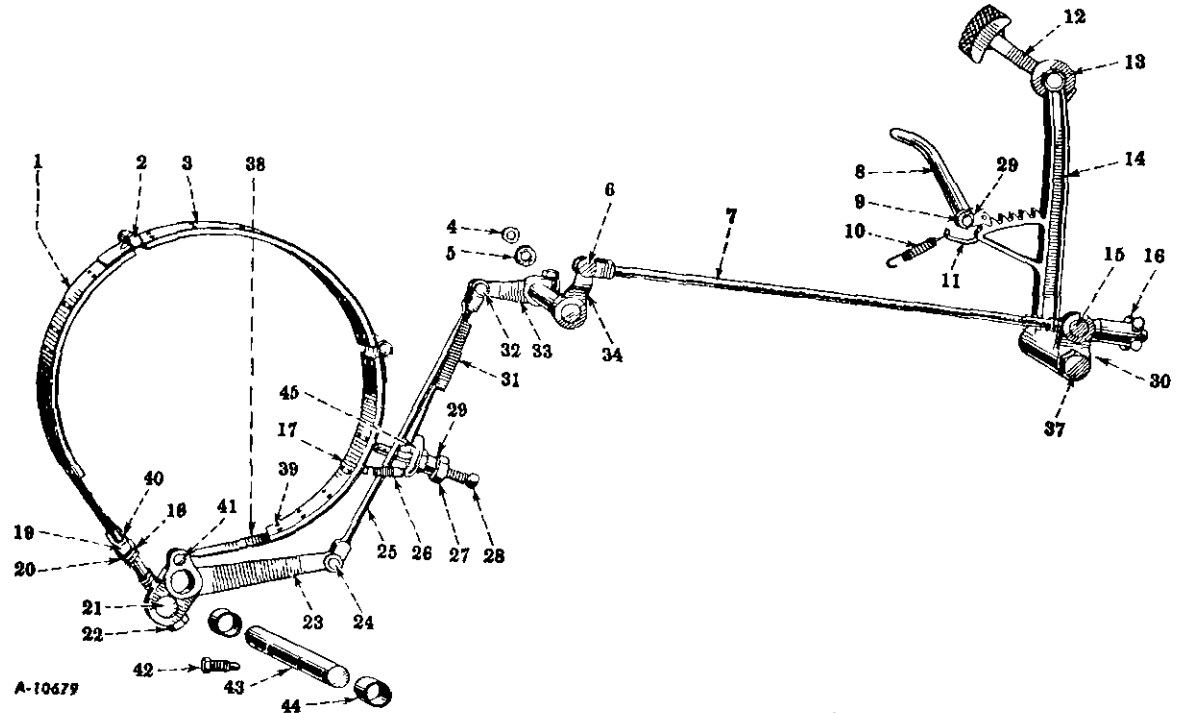

Illustr. 18 - Component Parts of Steering Brake Assembly. (Not Floating Pivot Type.)

- | | | | |
|------------------------|----------------------------|-----------------------------|----------------------------|
| 1. Rear brake band. | 13. Swivel. | 24. Rod end pin. | 37. Pedal shaft. |
| 2. Joint pin. | 14. Brake pedal. | 25. Inner rod. | 38. Front brake band. |
| 3. Center brake band. | 15. Pivot pin. | 26. Anchor spring. | 39. Brake band rivets. |
| 4. Lever key. | 16. Adjusting knob. | 27. Hex nut. | 40. Adjusting bolt spacer. |
| 5. Dirt seal. | 17. Brake band lining. | 28. Set screw. | 41. Pivot joint pin. |
| 6. Rod and pin. | 18. Release spring washer. | 29. Lock washer. | 42. Pivot shaft stud. |
| 7. Steering brake rod. | 19. Hex nut. | 30. Pedal shaft lubricator. | 43. Pivot shaft. |
| 8. Ratchet pawl. | 20. Release spring. | 31. Release spring. | 44. Pivot lever bushing. |
| 9. Pawl stud. | 21. Adjusting pin. | 32. Rod end pin. | 45. Spring anchor. |
| 10. Pawl spring. | 22. Adjusting bolt. | 33. Inner brake lever. | |
| 11. Pawl link. | 23. Pivot lever. | 34. Outer brake lever. | |
| 12. Pedal pad and rod. | | | |

Floating Pivot Type

Reassembly

Reassemble in the reverse order of disassembly except for the reassembly of the front and center brake bands. To reassemble these bands, proceed as follows:

1. Place the front and center brake bands in position and start the joint pin (25, Illust. 16) through the hinges.

NOTE: Do not leave the pin go beyond the first loop of the center band hinge.

2. Install the spreader. (Not used on 141, 142, 150, 151, 181, 182, 200 and 201 series tractors.)

3. Using an extra joint pin, or a drift, line up the hinges and press the pin all the way through.

4. Install the retaining spring on the joint pin. If equipped with a "TRUARC" snap ring, install with "TRUARC" standard No. 2 pliers with 90 degree tip (Illust. 19).

continued on next page



STEERING BRAKES

7. ASSEMBLY AND INSTALLATION - Continued

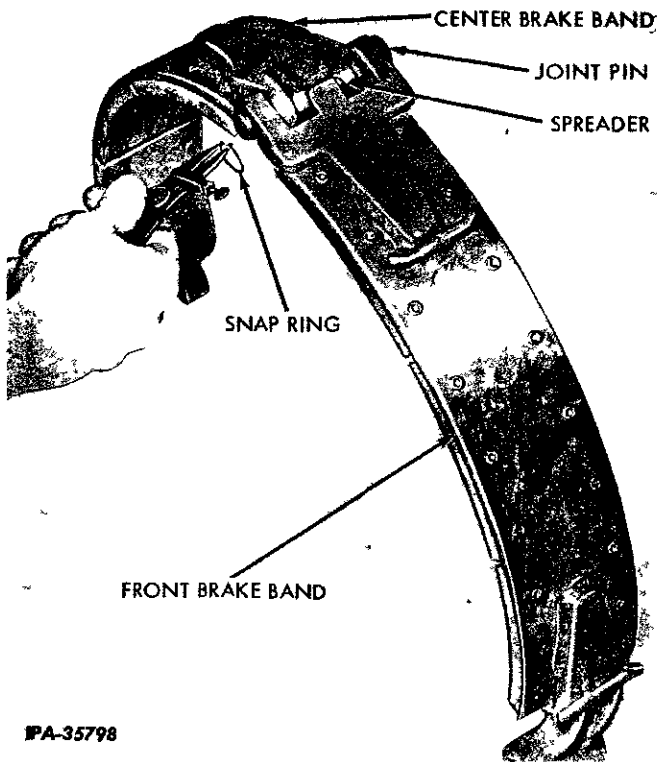

Illust. 19 - Installing Joint Pin Snap Ring.

INSTALLATION

1. Install the front and center brake bands and push up and around the brake drum until the rear hinge of the center band comes to the opening (Illust. 15).

2. Place the rear band in front of the center band and start the joint pin through the hinges (Illust. 14).

NOTE: Do not push the joint pin beyond the first loop of the center band hinge.

3. Install the spreader. (If used.)

4. Using an extra joint pin or a cap screw, line up the hinges and press the joint pin all the way through (Illust. 21).

5. Push the brake bands up and around the rear of the brake drum and attach the top anchor spring to the anchors.

ISS-1033Y. 8-61.

6. Push the brake band up and around the front of the brake drum and attach the lower anchor spring to the anchors.

7. Install the anchor bracket assembly (Illust. 13) and secure with four cap screws and lock washers.

8. Install the joint pin (Illust. 20).

NOTE: A screwdriver can be used to line up the holes.

9. Install the retaining spring or "TRUARC" snap ring (if equipped).

NOTE: A screwdriver can be used to help position the snap ring.

10. Install the adjusting clevis pin and retaining spring or "TRUARC" snap ring (if equipped) (Illust. 22).

11. Install the pivot lever and inner brake rod pin and cotter pin or "TRUARC" snap ring (if equipped) (Illust. 23).

12. Install the adjusting set screw in the main frame.

13. Adjust the brakes as outlined under "MAJOR ADJUSTMENT".

14. Install the inspection cover (Illust. 8).

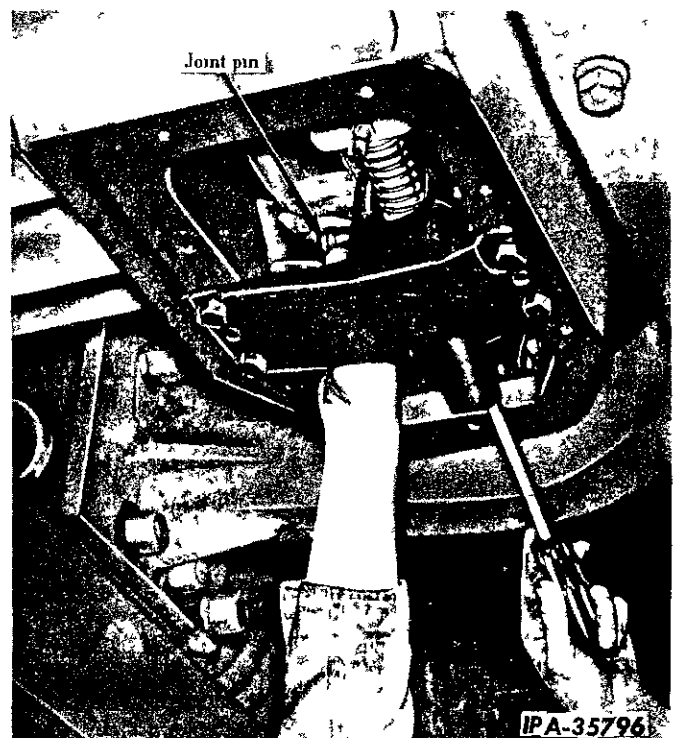

Illust. 20 - Installing Joint Pin.



STEERING BRAKES

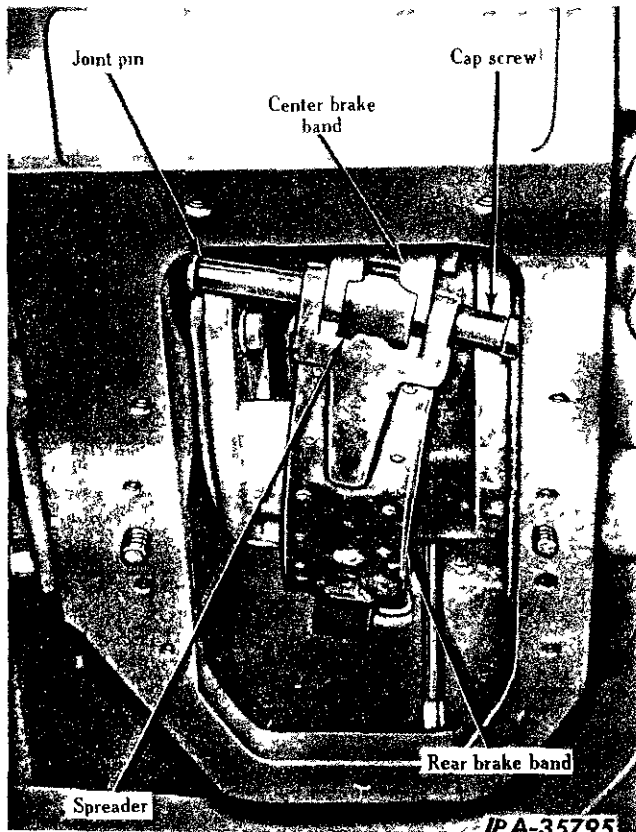

Illust. 21 - Installing Rear Brake Band Joint Pin.

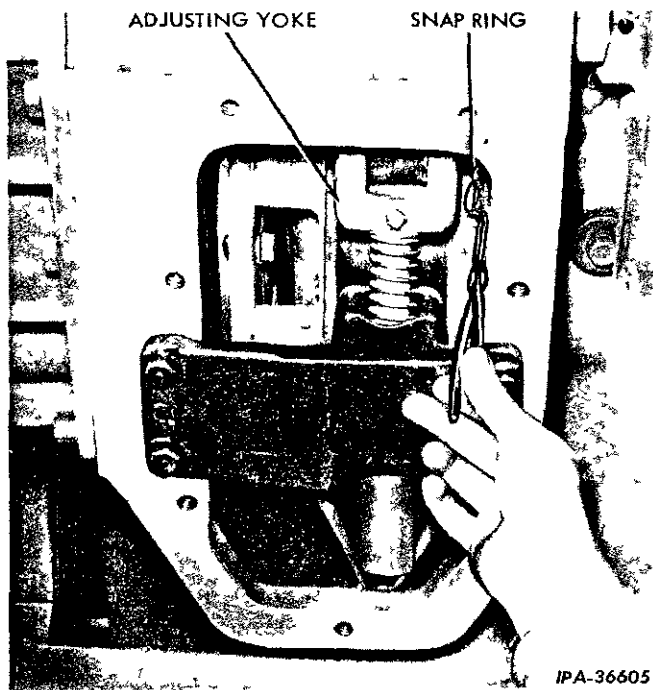

Illust. 22 - Installing Adjusting Yoke Pin Snap Ring.

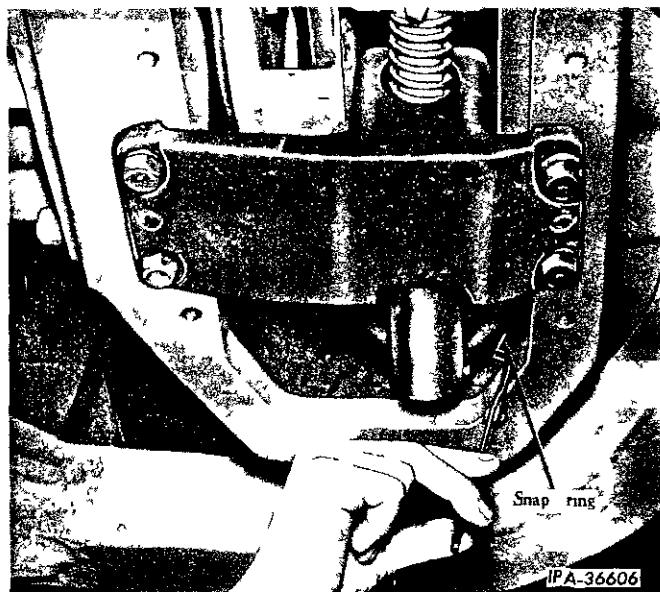

Illust. 23 - Installing Lower Brake Rod Pin Snap Ring.

8. ADJUSTMENT (See Illust. 25)

Floating Pivot Type

Minor Adjustment

1. Remove the drain plug "B" (Illust. 24) from the front of the lower inspection cover.

continued on next page

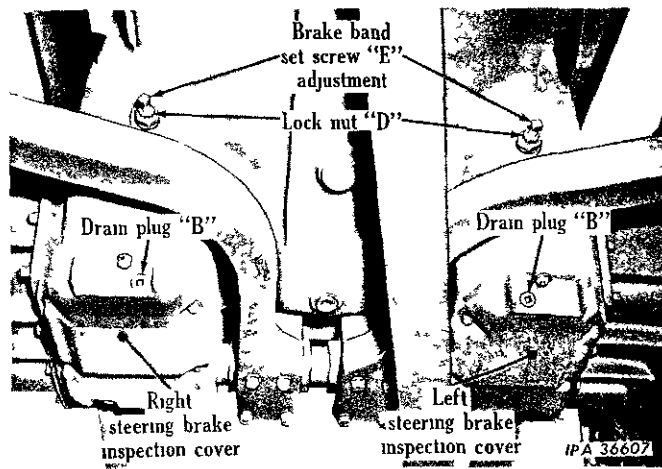

Illust. 24 - Steering Brake Inspection Covers.



STEERING BRAKES

8. ADJUSTMENT (See Illust. 25) - Continued

Floating Pivot Type - Continued

Minor Adjustment - Continued

2. Insert a wrench with a 1/2 inch drive extension through the opening and tighten nut "A"

(Illust. 26) until the brake bands are touching the drum (nut will be tight), then back off three notches (1-1/2 turns).

3. Replace drain plug "B" (Illust. 24).

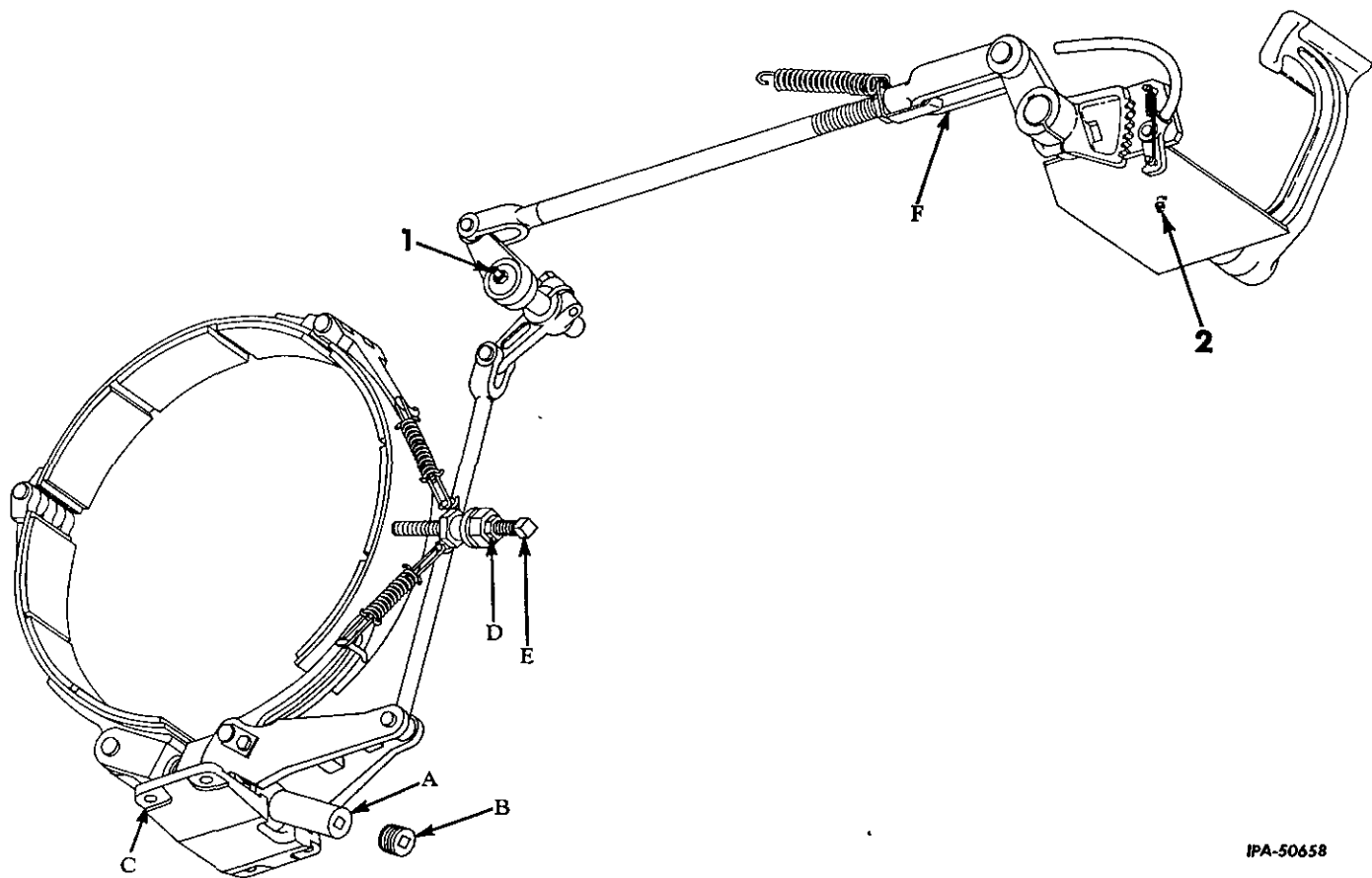

Illust. 25 - Steering Brake Adjustment (Floating Pivot Type).
(Ref. Nos. 1 and 2 are lubricating fittings.)

IPA-50658

Major Adjustment

This adjustment is to be made only when the brake bands have been removed or after the minor adjustment above has been made twice.

1. Remove the lower inspection cover (Illust. 8).

2. Tighten nut "A" (Illust. 26) until the brake bands are touching the drum, then back off three notches (1-1/2 turns).

3. Apply the brakes and set the brake locks.

4. Loosen lock nut "D" (Illust. 24).

5. Adjust set screw "E" (Illust. 24) until there is 1/32 inch clearance between the set screw and the brake band, then tighten lock nut.

6. Release the brakes.

7. Loosen lock nut and adjust set screw "C" (Illust. 27) until there is 1/32-inch clearance between the brake band and the brake drum; tighten lock nut.

8. Replace the inspection cover.



STEERING BRAKES

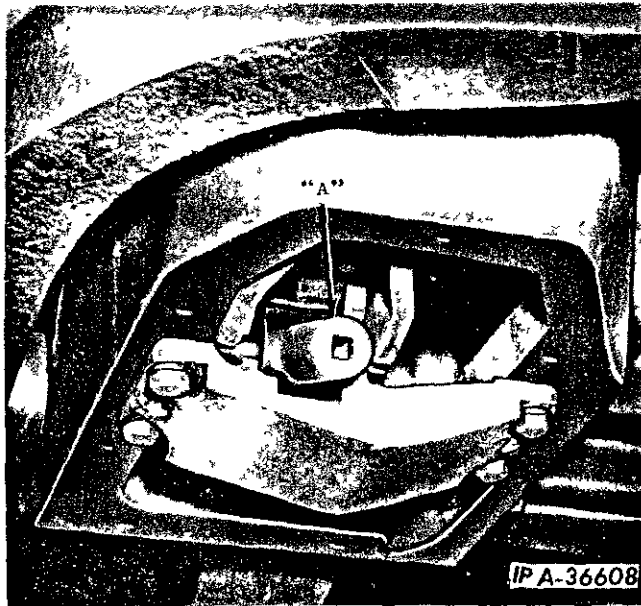

Illust. 26 - Inspection Cover Removed.

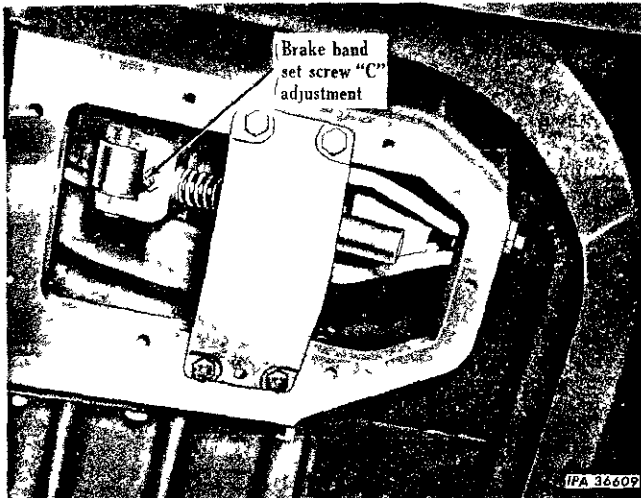

Illust. 27 - Brake Band Adjustment Set Screw "C."

Not Floating Pivot Type

(See Illusts. 28 and 29)

1. Turn the brake rod adjusting knobs "A" on each side of the tractor (located under the dash and just above the main frame side channels)

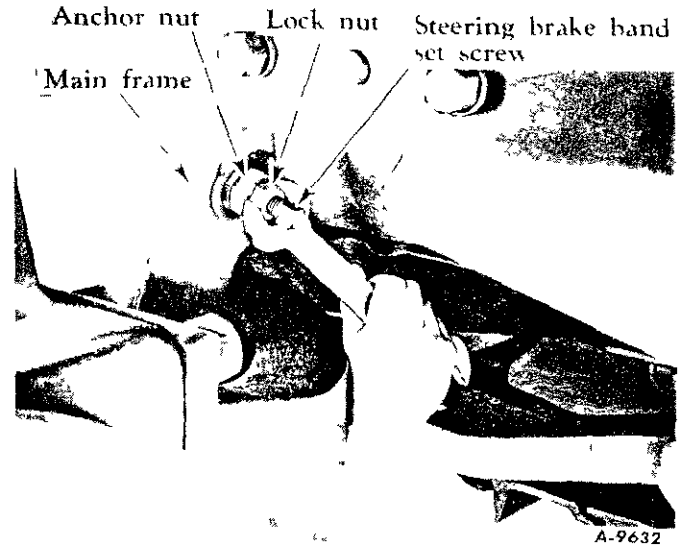

Illust. 28 - Adjusting Steering Brake Band Set Screw.

clockwise until the desired pedal travel has been obtained.

2. When adjustment can no longer be made with the knobs "A", turn the knobs counter-clockwise until about 1 inch of threads on the brake rods remains covered. Then remove the brake inspection covers located under the rear section of the main frame on each side of the tractor.

3. Adjust the brake band set screw "E" to give 1/64-inch clearance between the steering clutch drum and the lining at that point, and lock the set screw. The set screw is accessible from the outside of the tractor.

4. Loosen the jam nut "B" and turn the steering brake band adjusting bolt "C" until 1/64-inch clearance has been obtained between the steering clutch drum and the brake lining at all points.

5. Lock the jam nut "B," install the covers, and adjust the knobs "A" to give three inches free pedal movement.

6. Subsequent intermediate adjustments can be made with the adjustment knobs "A."

continued on next page



STEERING BRAKES

8. ADJUSTMENT - Continued

Not Floating Pivot Type - Continued

(See Illusts. 28 and 29) - Continued

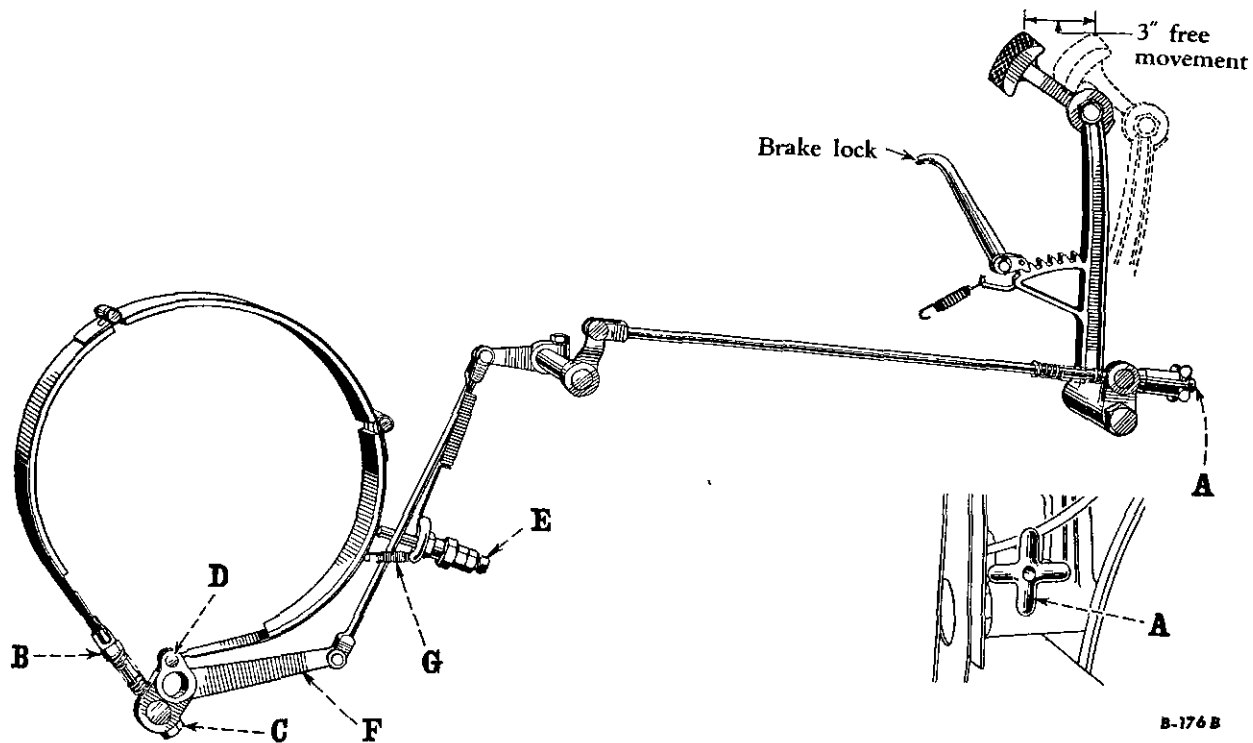

Illust. 29 - Steering Brake Adjustment (Not Floating Pivot Type).

STEERING CLUTCHES

9. REMOVAL

1. Drain the oil from the transmission.
2. Remove the platforms.
3. Remove the seat frame, fenders and fuel tank, disconnecting the fuel lines, vent lines, battery and all electrical wiring in advance. Remove the battery.

NOTE: Disconnecting the vent lines is covered in "Transmission and Bevel Gear," Section 6.

4. Drain the hydraulic booster system by removing the drain plug in the suction line.

ISS-1033Y. 8-61.

Disconnect the two pressure lines at the booster end and the suction line from the booster at the connector hose. On the 15 and 20 series tractors, remove the two pressure lines from the hydraulic pump end only; disconnect the suction line at the tee and remove the booster with the hoses connected.

5. Remove the gear shifter housing and the steering clutch controls. (See "Transmission and Bevel Gear," Section 6.)
6. Remove the main frame cover (see "Transmission and Bevel Gear," Section 6).



STEERING CLUTCHES

NOTE Keep the transmission and bevel gear compartments covered to prevent dirt or other objects from falling into the compartments.

7. Remove the grease tubes from the release bearing and the release fork lower bearing. (See Illust. 30.) Remove the lower cotter pin from the upper shift link pin and lift the pin out. (See Illust. 31.) Remove the upper cotter pin from the lower link pin. Raising the release fork slightly will allow the lower link pin to drop out and the lower shift link can be removed. Remove the release fork.

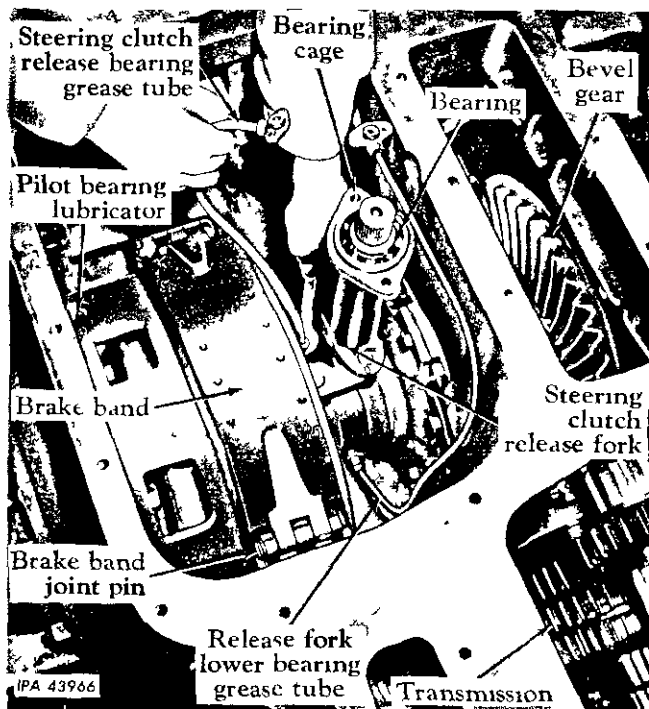

Illust. 30 - Removing Grease Tubes.

8. Disconnect the brake band by removing the spring clip, cotter pin or "TRUARC" snap ring which secures the joint pin. ("TRUARC" snap ring pliers, either off-set or straight, are desirable for either installation or removal.) Remove the pins holding the center segment of the brake band and lift out the segment.

9. Remove the eight cap screws in the bearing cage cap and pry the cap loose. (See Illust. 32.)

10. Cut the lockwire on the six cap screws which secure the two half-moon shaft coupling retainers. Remove the three cap screws from each retainer. Work on the accessible cap

screws only and as the clutch drum is turned (see next step) the remaining ones will be accessible.



Illust. 31 - Removing Collar Shift Pin.

11. Remove all accessible cap screws holding the steering clutch drum to the flange of the sprocket drive pinion shaft. It will be necessary to rotate the clutch drum to bring up the cap screws to be removed. Use a large pry bar and, to gain the leverage necessary, place on the track frame and wedge against a sprocket tooth. This prying action will move the tractor and rotate the drum. Remove all but one cap screw (see Illust. 33), and with a chisel, mark the clutch drum and pinion drive shaft flange, because the holes in the flange and drum are not evenly spaced, therefore they can be installed one way only. The one cap screw remaining is holding the drum assembly.

12. Install a cable sling (see Illust. 34) to help support the weight of the drum assembly. Use a pry bar and move the steering clutch shaft coupling into the bearing cap.

continued on next page



STEERING CLUTCHES

9. REMOVAL - Continued

13. Take up the slack in the cable and remove the last cap screw holding the steering clutch to the flange. With the assistance of a pry bar, move the clutch away from the flange and lift the clutch out of the compartment, being careful not to bump the nut on the shaft, against the main frame.

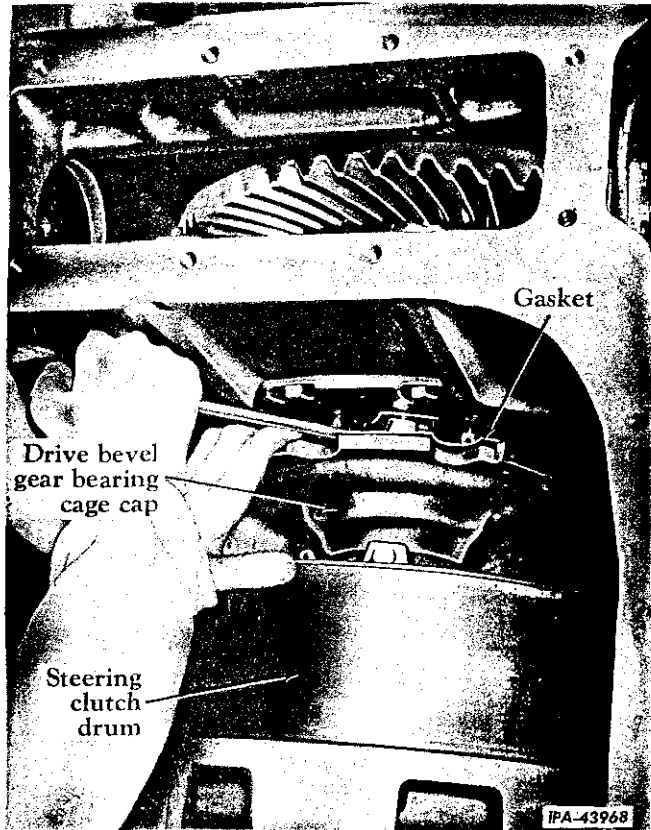

Illust. 32 - Pry Bearing Cage Cap Loose.

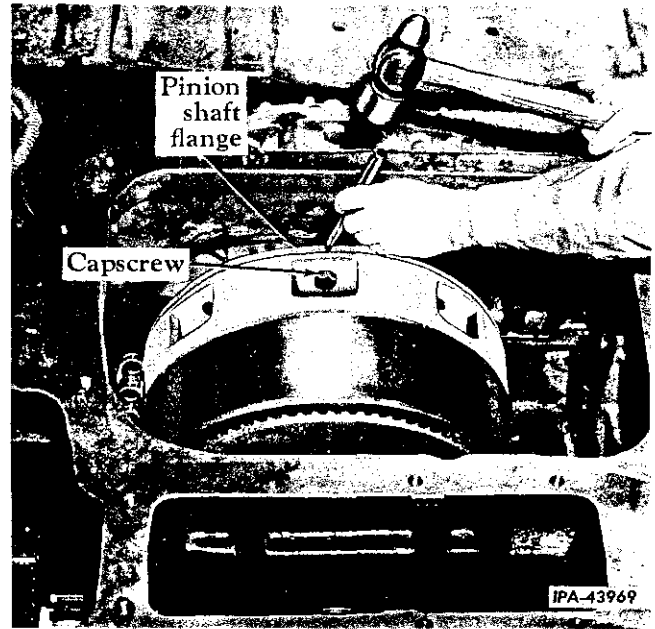

Illust. 33 - Marking the Clutch Drum and Pinion Drive Shaft Flange with Chisel.

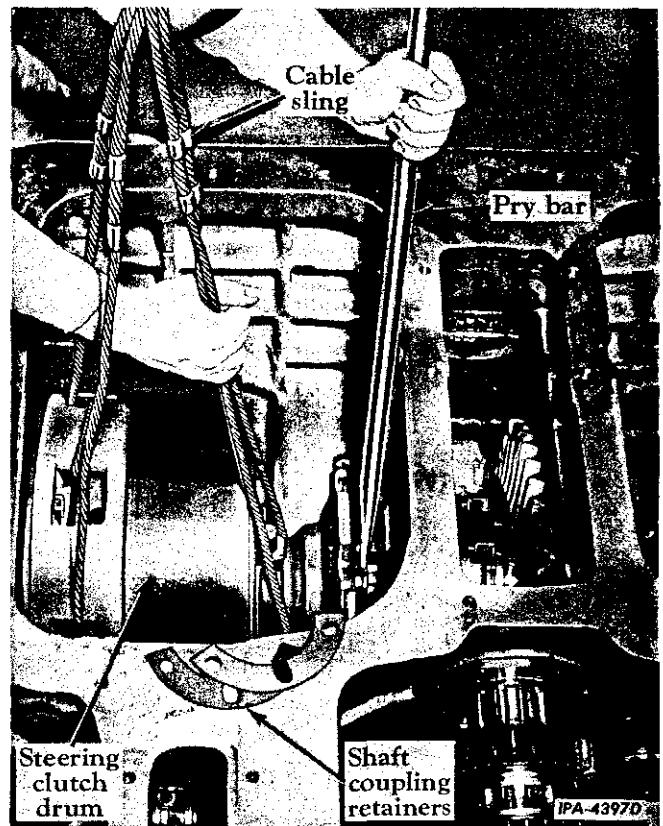

Illust. 34 - Removing Steering Clutch from Compartment Using Cable Sling.



STEERING CLUTCHES

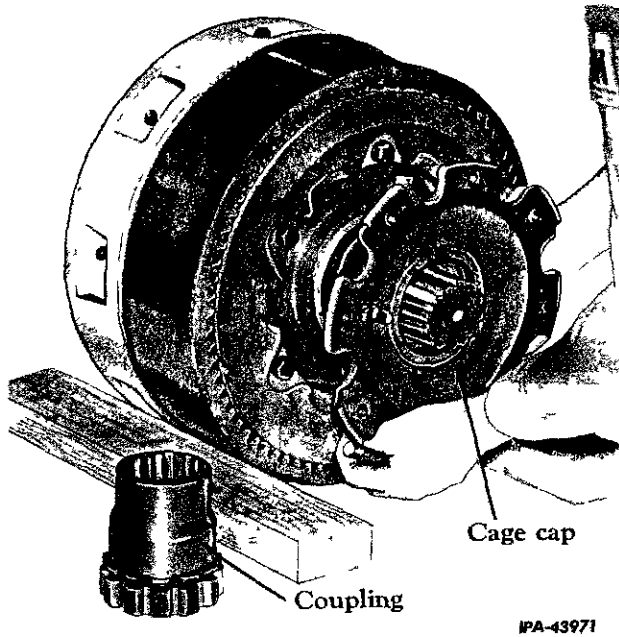

IPA-43971

Illust. 35 - Removing Steering Clutch Cage Cap.

out from the inside of the drum without removing the retaining snap ring.

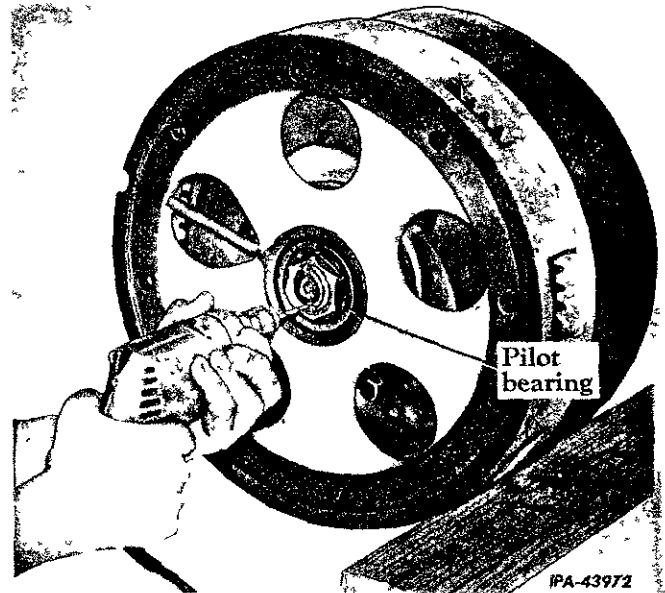

IPA-43972

Illust. 36 - Relieving the Stake on Pilot Bearing Retainer Nut.

10. DISASSEMBLY

1. Remove the coupling and bearing cage cap from the shaft. (See Illust. 35.)

2. Un-stake the pilot bearing retaining nut. (See Illust. 36.) Drill a 5/32 inch hole no more than 1/4 inch deep at the point of staking, and outside the radius of the threads. The second hole should be drilled directly across from the first. The nut can now be turned off. Earlier tractors were equipped with a steering clutch pilot bearing retainer, pin and bolt, instead of a nut.

3. Install three 1/2-inch bolts through the holes in the drum and into the pressure plate until they bear against the hub. This will relieve the spring pressure for removing the hub plate later.

4. Drive the splined shaft out with a soft mallet. The pilot bearing spacer will drop off the shaft as the shaft is withdrawn. (See Illust. 37.)

5. Support the clutch, as shown in Illust. 40, and remove the drum. Tap the pilot bearing

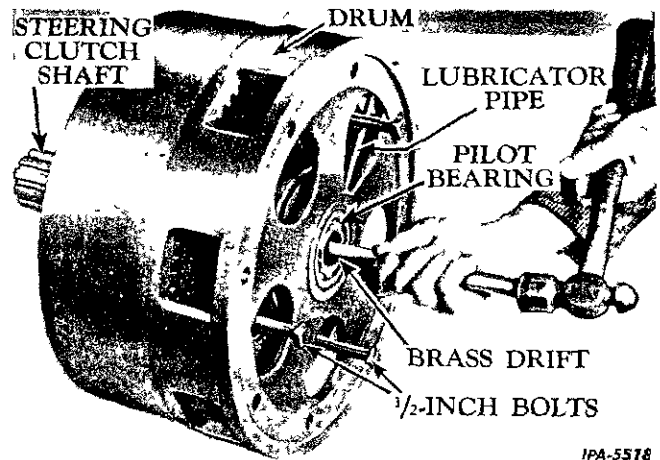

IPA-5578

Illust. 37 - Driving Out Steering Clutch Shaft.

6. Invert the clutch (Illust. 41) and remove the clutch plate and discs.

continued on page 22



STEERING CLUTCHES

10. DISASSEMBLY - Continued

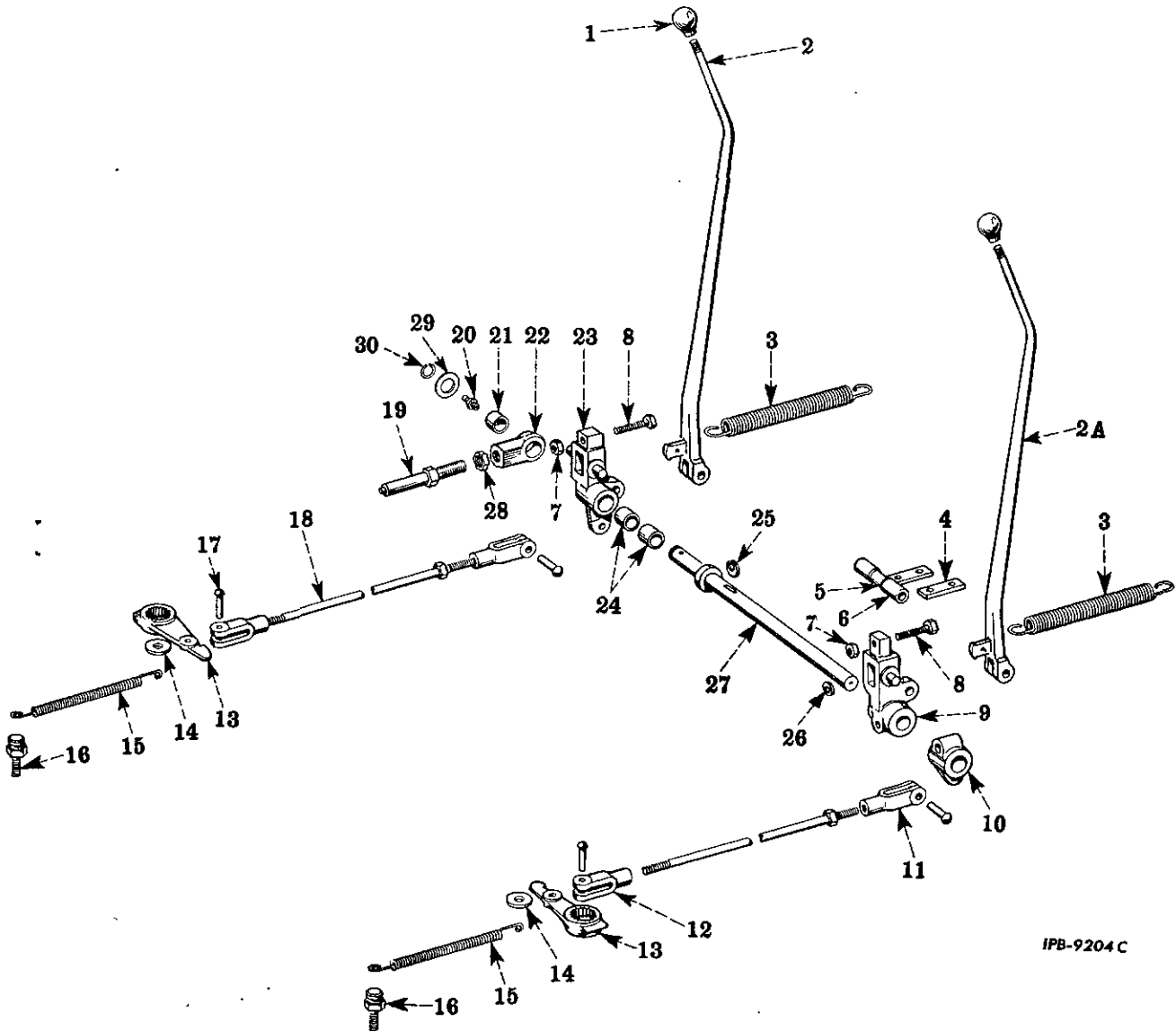

IPB-9204 C

Illust. 38 - Exploded View of Steering Clutch Controls.

- | | |
|---------------------------------------|---|
| 1. Hand lever ball. | 16. Release lever return spring anchor. |
| 2. Hand lever (LH). | 17. Operating rod yoke pin. |
| 2A. Hand lever (RH). | 18. Operating rod. |
| 3. Hand lever return spring. | 19. Hand lever shaft tie rod. |
| 4. Hand lever stop retainer. | 20. Hand lever shaft lubrication fitting. |
| 5. Hand lever stop with bumpers. | 21. Hand lever shaft tie rod adjusting eye bushing. |
| 6. Hand lever stop bumper. | 22. Hand lever shaft tie rod adjusting eye. |
| 7. Hand lever hub adjustment jam nut. | 23. Hand lever hub (LH). |
| 8. Hand lever hub adjustment screw. | 24. Hand lever hub bushing. |
| 9. Hand lever steering hub (RH). | 25. Hand lever arm key (LH). |
| 10. Hand lever arm. | 26. Hand lever arm key (RH). |
| 11. Operating rod yoke (RH). | 27. Hand lever shaft. |
| 12. Operating rod yoke (LH). | 28. Hand lever shaft tie rod adjusting nut. |
| 13. Release lever. | 29. Hand lever shaft washer. |
| 14. Release lever retainer washer. | 30. Hand lever shaft snap ring. |
| 15. Release lever return spring. | |



STEERING CLUTCHES

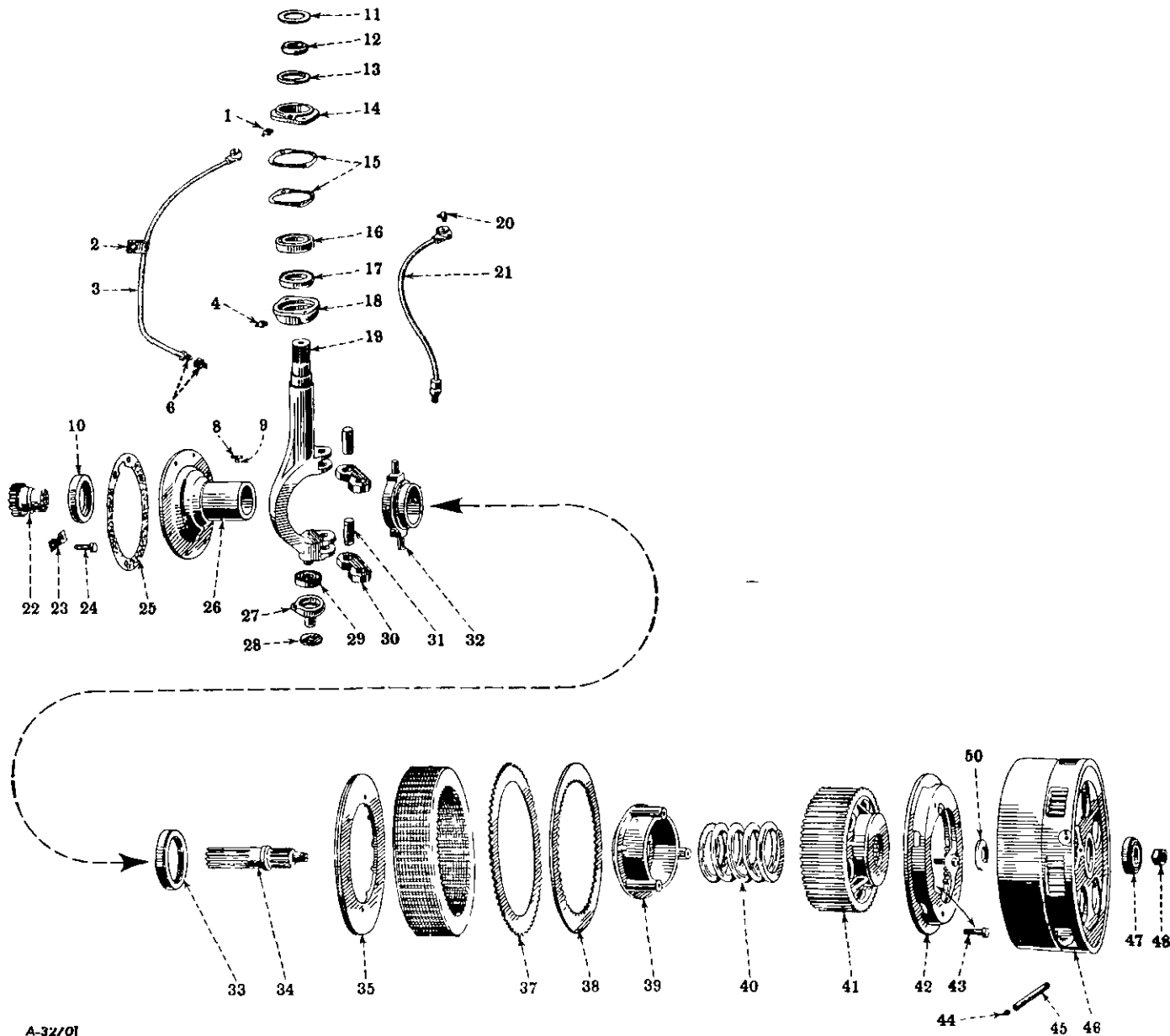

A-32/01

Illust. 39 - Exploded View of Steering Clutch Mechanism (14 Series Shown).
(15, 18 and 20 Series Similar.)

- | | | |
|-----------------------------|---------------------------------|--------------------------------|
| 1. Lubricator. | 19. Release fork. | 34. Clutch shaft. |
| 2. Clamp. | 20. Lubricator. | 35. Hub plate. |
| 3. Grease tube. | 21. Grease tube. | 37. Driving disc. |
| 4. Lubricator. | 22. Shaft coupling. | 38. Friction disc. |
| 6. Connector with nut. | 23. Coupling retainer. | 39. Pressure spring retainer. |
| 8. Collar key. | 24. Coupling bolt. | 40. Pressure spring. |
| 9. Collar key pin. | 25. Gasket. | 41. Hub. |
| 10. Coupling oil seal. | 26. Bearing cage cap. | 42. Pressure plate. |
| 11. Felt retainer. | 27. Lower bearing pivot. | 43. Pressure plate dowel bolt. |
| 12. Lever spacer. | 28. Pivot retainer. | 44. Pilot bearing lubricator. |
| 13. Felt. | 29. Lower release fork bearing. | 45. Lubricator pipe. |
| 14. Upper bearing retainer. | 30. Shifter link. | 46. Drum. |
| 15. Gaskets. | 31. Link pin. | 47. Pilot bearing. |
| 16. Upper bearing. | 32. Release collar. | 48. Nut. |
| 17. Oil seal. | 33. Thrust bearing. | 50. Bearing spacer. |
| 18. Cage. | | |



STEERING CLUTCHES

10. DISASSEMBLY - Continued

7. Place the hub and spring retainer in an arbor press (Illust. 42) and apply pressure on the spring retainer. Remove the three 1/2-inch bolts and the three spring retainer dowel bolts. Release the pressure of the press ram slowly until the spring is fully extended, then lift off the pressure plate, hub, spring and retainer. (See Illust. 43.)

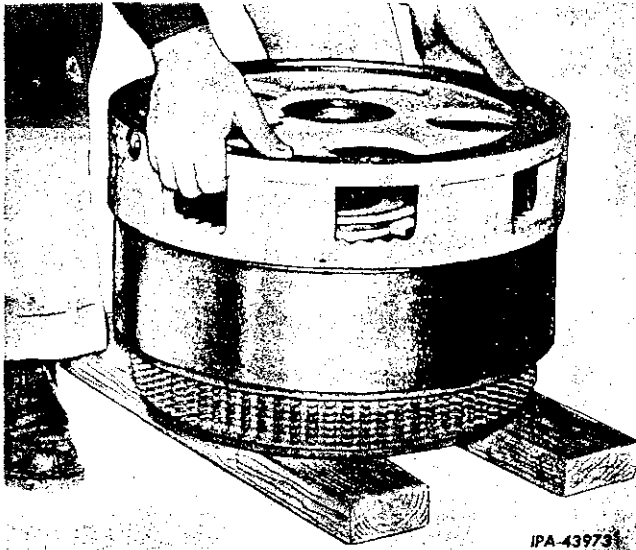

Illust. 40 - Removing Clutch Drum.

IPA-43973

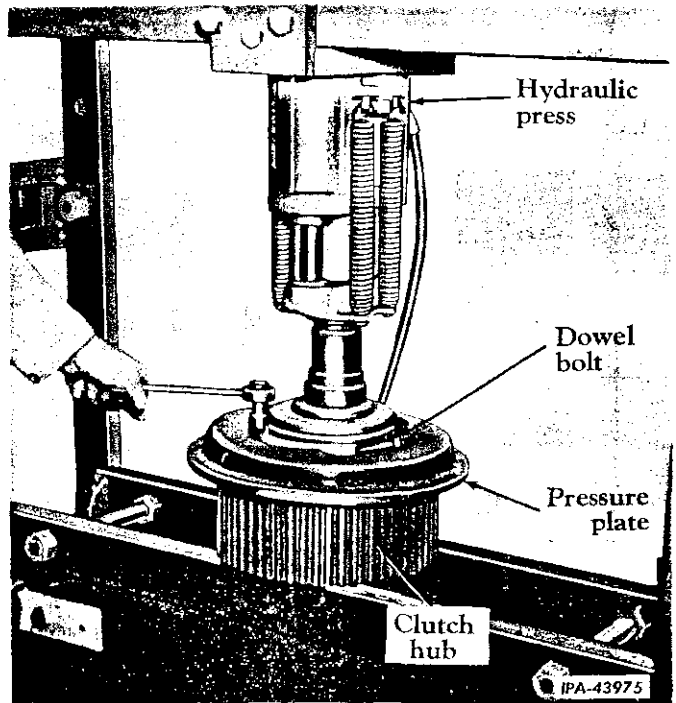

Illust. 42 - Removing Pressure Plate Dowel Bolts.

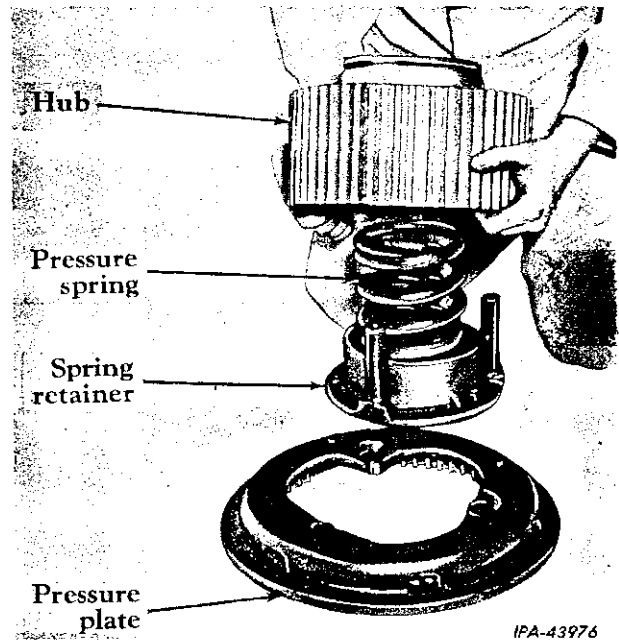

Illust. 43 - Removing Hub from Spring Retainer.

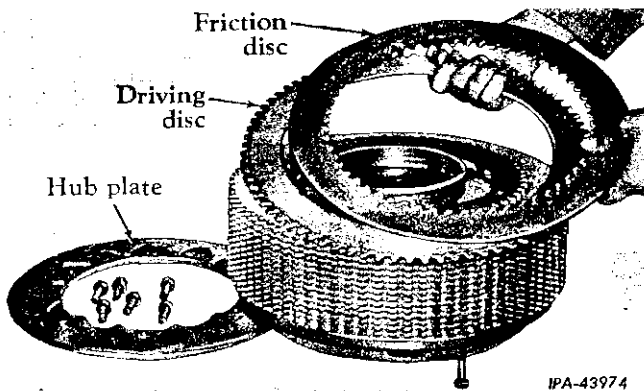

Illust. 41 - Removing Friction and Driving Discs.

11. INSPECTION AND REPAIR

1. BEARINGS. The release thrust bearing and lower release fork bearing can be inspected



STEERING CLUTCHES

without removing them from the release collar and release fork. If all bearings, including the pilot bearing and upper release fork bearing, are in good condition, thoroughly grease them and cover them until ready for assembly.

2. **DRUM AND HUB.** Check the surface of the drum for scoring. A scored drum can be placed in a lathe and turned down not to exceed 0.015 inch. If it does not clean up, replace with a serviceable drum. See paragraph 6 "Relining Bands" for information regarding the turning down of undersize drums and relining the bands with 1/2" lining. Check the teeth inside of the drum and outside of the hub for wear. Movement of the clutch disc may develop notches in the teeth. Replace either the drum or the hub if the teeth are worn excessively. Small burrs can be removed with a stone. The outside of the hub and the inside of the spring retainer must be smooth.

3. **DISCS.** Place the discs one at a time on a surface plate or under a straightedge to check for warping. If a 0.005 inch feeler gauge can be inserted between the disc and surface plate or straightedge, replace the discs. If disc teeth are damaged, replace the discs.

4. **PRESSURE SPRING.** Replace the spring if it is cracked or broken, or if it does not come up to specifications given in paragraph 2.

5. **OIL SEAL:** Inspect the oil seal in the bearing cap and if the seal is mutilated or oil has been leaking into the clutch compartment, replace with an oil-soaked seal, placed so that the lips of the seal face toward the coupling. The coupling can be used to drive in the seal.

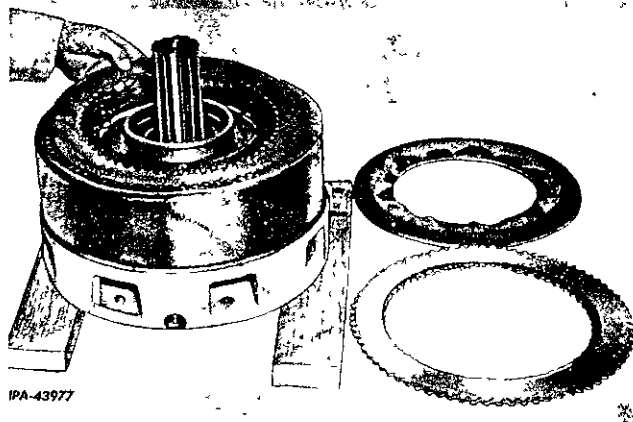

Illust. 44 - Installing Steering Clutch Discs.

Inspect the oil seal in the upper release bearing cage and replace if necessary, with the lip facing toward the bearing.

6. Inspect all parts for wear and damage and replace if necessary.

12. ASSEMBLY

(Refer to Illust. 39)

1. Install the steering clutch spring (40) in the retainer (39). Place the hub (41) over the spring. Position the pressure plate (42) on the hub so that the prongs of the retainer (39) are in alignment with the holes in the hub (41).

2. Place the unit in an arbor press and compress the spring. (See Illust. 42.) Install the dowel bolts (43) and lock washers, and install the 1/2-inch bolts in the tapped holes in the pressure plate (42) to hold the spring compressed, as shown in Illust. 37. Remove the unit from the arbor press.

3. Tap the pilot bearing (47) in place in the drum (46) from the outside. The bearing spacing ring will determine the depth to which it is to be installed.

4. Insert the clutch shaft (34), short splined end first, into the hub (41) and set on splined end of shaft. Place the bearing spacer (50) on the shaft, with the flat side down.

5. Position the drum (46) over the pressure plate and lower it over the shaft; the pilot bearing will center the shaft correctly. The shaft nut (48) can now be put on and tightened sufficiently to hold, but not torqued until later. Invert the whole assembly on two 2 x 4's to take the direct load off the bearing.

NOTE: Earlier models were equipped with a pilot bearing retainer, retainer pin and retainer bolt, instead of shaft nut (48).

6. Install the steering clutch discs, starting with the friction (inner tooth) disc (38), then driving (outer tooth) disc (37), continuing this until all have been installed. Bolt the hub plate (35) in place and tighten. (See Illust. 45.) Remove the three 1/2-inch bolts that were used to hold the pressure spring tension in step (2). Torque the pilot bearing retainer nut as specified in paragraph 2, and stake the nut.

continued on next page



STEERING CLUTCHES

12. ASSEMBLY - Continued

(Refer to Illust. 39) - Continued

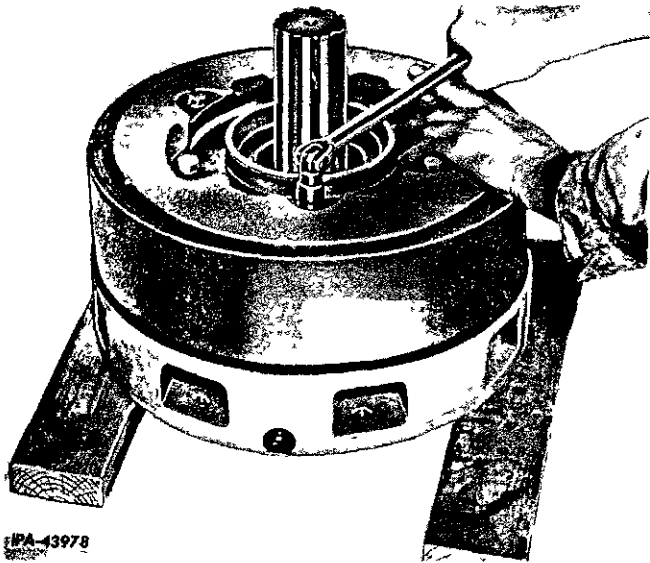

Illust. 45 - Tightening the Hub Plate Cap Screws.

7. Slide the release collar (32) with bearing (33) on the bearing cage cap (26) with the lubricator fitting facing toward the rear of the tractor when the steering clutch is installed. Coat the finished surface on the cage cap (26) with SAE-30 oil before sliding the collar on.

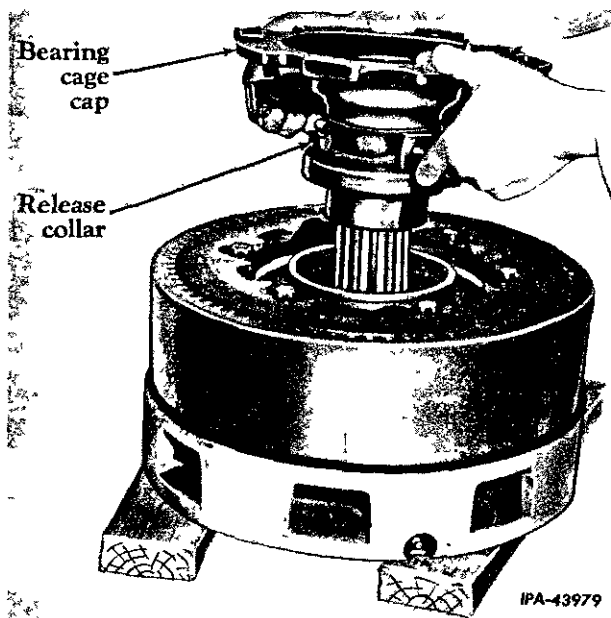

Illust. 46 - Installing the Release Collar and Bearing Cage Cap on Clutch Shaft.

8. Slide the cage cap (26) with oil seal (10), on the clutch shaft (34) and insert the coupling (22) on the shaft. (Illust. 46.) The steering clutch is now ready for installing.

13. INSTALLATION

1. TD-14A AND TD-18A ONLY: Install the release fork lower bearing cage, with grease tube, in the bottom of the steering clutch compartment.

2. Install a cable sling around the bearing cage cap and through two openings in the drum in such a way as to have the chisel mark at the top. (See Illust. 33.) Place a new bearing cage cap gasket in position. Lower the steering clutch into the compartment and align the chisel marks on the sprocket drive pinion shaft flange and the clutch drum.

Install a cap screw in the upper side of the drum to support it. With a pry bar, move the clutch shaft coupling into the bevel gear hub. Install as many cap screws as there are holes accessible to hold the steering clutch drum to the flange of the sprocket drive pinion shaft.

If the splines do not line up, use a pry bar to rotate the clutch drum. If this movement is not enough, it will be necessary to move the tractor slightly with a pry bar or jack until the splines line up. Hold the drum so it does not rotate when the tractor is being moved. Pry the coupling in and remove the sling. (See Illust. 47.)

3. TD-14A AND TD-18A ONLY: Install the cap screws with locks, and bend the locks over the sides of the screw heads. Attach the bearing cage cap to the bearing cage and main frame.

TD-14 (141 AND 142), TD-15 (150 AND 151), TD-20 (200 AND 201) AND TD-18 (181 AND 182) ONLY: Install a cap screw in the bevel gear hub and slip one of the two coupling retainers in place. Install the other two cap screws, but do not tighten as yet.

The tractor must now be moved to rotate the steering clutch. As the holes in the clutch drum and the drive shaft flange come up and are accessible, install the cap screws. The other coupling retainer should now be installed, tightening the cap screws and lock-wiring them.



STEERING CLUTCHES

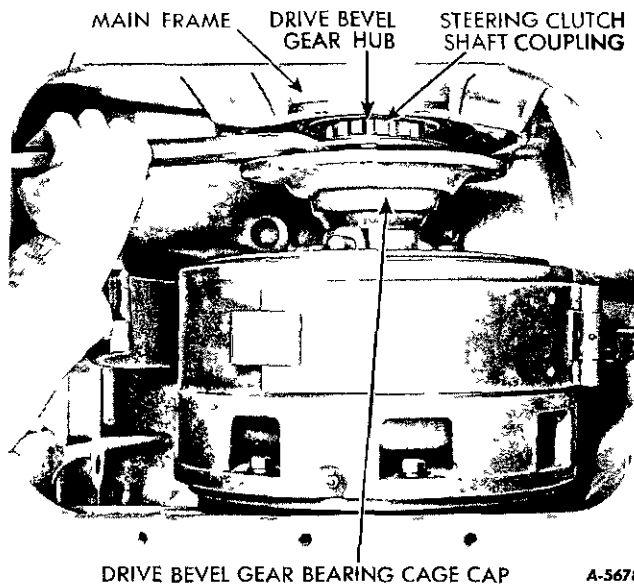

Illustr. 47 - Inserting Steering Clutch Shaft Coupling into Drive Bevel Gear.

The clutch drum must be rotated again until the first coupling retainer is accessible; the cap screws should now be tightened and lock-wired.

4. TD-14A AND TD-18A ONLY: Install the lower release fork bearing and the upper cage with oil seal and bearing on the release fork. Install the lower link pin in the fork; lock the bottom cotter pin and install the upper cotter pin, but do not lock it. Place the release fork in position and tap the lower bearing into the cage at the bottom of the main frame. The fork must be between the clutch collar and the rear of the tractor. Place the lower shift link on the release collar pin. Remove the top cotter pin from the shift link pin and insert this pin through the link; reinstall the cotter pin and lock it. Install the upper shift link pin. (See Illustr. 31.)

TD-14 (141 AND 142), TD-15 (150 AND 151), TD-20 (200 AND 201) AND TD-18 (181 AND 182): Place the release fork in positions securing it with the link pins and cotter pins. (Illustr. 39.) The steps in "REMOVAL," Par. 9, can be reversed for "INSTALLATION." Connect the grease tubes to the release bearing and the release fork lower bearing. (Illustr. 30.) Lubricate the pins when installing them.

5. Connect the brake band by replacing the joint pin or pins and securing with a cotter pin or "TRUARC" snap ring, whichever is used.

6. Install the main frame cover.

7. Install the gear shifter housing and steering clutch controls.

8. Connect the suction and two pressure lines of the hydraulic booster system. Replace the drain plug in the suction line and fill the oil reservoir to the proper level as specified in the "Operator's Manual."

9. Install batteries, all electrical cables and wires, connect fuel lines and vent lines. Install the seat frame, fenders and fuel tank.

10. Install the platforms.

11. Fill the transmission with the amount and grade recommended, see the "Operator's Manual."

12. Adjust steering brakes. (Refer to paragraph 8.)

13. Adjust steering clutches. (Refer to paragraph 15.)

14. Adjust the steering clutch levers. (Refer to paragraph 15.)

15. Operate the tractor and try both brakes and steering clutches.

14. STEERING CLUTCH CONTROLS (Refer to Illustr. 38)

Disassembly

1. Remove the lubrication fitting (20).
2. Remove the snap ring (30), washer (29) and the adjusting eye (22) from the shaft (27).
3. Remove the hand lever (2) with hub (23) and linkage from the shaft (27).
4. Remove the bolts, nuts and lockwashers which clamp the hand lever hub (9) and hand lever arm (10) to the shaft (27).
5. ALL TRACTORS EXCEPT TD-15 AND TD-20 SERIES: Tap the shaft (27) to the left until the two keys (25 and 26) are exposed, and remove the keys from the shaft (27).
6. TD-15 AND TD-20 SERIES ONLY: Remove the special hand lever hub keys (25 and 26). (Illustr. 48.)

continued on next page



STEERING CLUTCHES

14. STEERING CLUTCH CONTROLS (Refer to Illust. 38)
- Continued

Disassembly - Continued

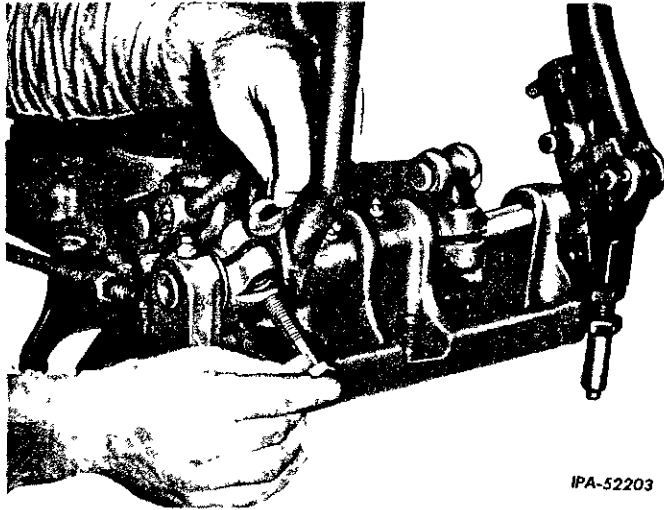

IPA-52203

Illust. 48 - Removing the Hand Lever Arm Key (TD-15 and 20 Series).

7. TD-15 AND TD-20 SERIES ONLY: Disconnect the forward-reverse shifter link from the forward-reverse shifter crank. This will allow the forward-reverse hand lever to be removed as the shaft (27) is removed.

8. Tap the shaft (27) to the left, and remove the arm (10), hub (9) and the forward-reverse hand lever (15 and 20 series only). Remove the shaft from the shifter housing.

9. The bushings (21) and (24) need not be removed unless replacement is necessary.

Reassembly

1. Slide the shaft (27) through the left-hand shaft support of the shifter housing.

2. Install the R.H. hub (9) on the shaft and continue to slide the shaft through the center support.

3. TD-15 AND TD-20 SERIES TRACTORS ONLY: Install the forward-reverse shift lever on the shaft (27).

4. Install the arm (10) on the shaft (27).

5. TD-15 AND TD-20 SERIES ONLY: Place the steering clutch hand lever washer on the shaft.

6. Slide the shaft into the right-hand shaft support of the shifter housing.

7. ALL TRACTORS EXCEPT TD-15 AND TD-20 SERIES: Slide the hub (9) to the right, against the shaft center support. Rotate the shaft until the keyway in the shaft is exposed and install the key (25). Slide the arm (10) to the left, against the shaft center support. Rotate the shaft until the keyway in the shaft is exposed and install the key (26). Align the keyways in the hub (9) and arm (10) with the keys (25 and 26), tap each into position and install the bolts, nuts and lock washers.

8. TD-15 AND TD-20 SERIES ONLY: Align the slot in the hub (9) with the keyway in the shaft (27). Install the special key (25) into the shaft, being sure to align the hole in the key with the holes in the hub. Install the bolt, nut and lock washer.

Move the R.H. clutch hand lever as far as possible to the rear. This will allow you to see the shaft keyway for the arm (10). Install the key (26) and the arm (10) in the same manner as outlined in the preceding paragraph.

9. TD-15 AND TD-20 SERIES ONLY: Connect the forward-reverse shifter link to the forward-reverse shifter crank, using the crank pin and cotter pin.

15. ADJUSTMENT

(See Illust. 49)

If the clutches slip, or if the free travel of the hand levers is incorrect, adjustment is necessary. To make the adjustment, proceed as follows:

1. Loosen the yoke lock nuts "D" and turn the rods "H" counterclockwise (facing toward front of tractor) to shorten the rods, or clockwise to lengthen the rods. Then tighten the lock nuts "D" against the rods.

2. Check to see if the free movement of the hand lever is within the minimum and maximum limits.

3. When adjustment can no longer be made by means of lengthening the operating rod, proceed as follows: Loosen the yoke lock nuts "D," remove the release lever return springs "A" and the operating rod yoke pins "C"; then remove the steering clutch release lever cap screws "F." Loosen the cap screws "G" and



STEERING CLUTCHES

pry the release levers "B" off the splined release shafts. Turn the right hand release lever clockwise and the left hand release lever counterclockwise slightly. Install the levers on the splined release shafts and reassemble the yoke pins "C." Then adjust the operating rods "H" until a free movement of from 2 to 4 inches has been obtained.

4. When the desired free movement of the hand lever has been obtained, install and tighten the release lever cap screws "F" and tighten the cap screws "G." Reassemble the release lever return springs "A".

5. Subsequent intermediate adjustments can be made by lengthening the rod linkage as described above.

2. Tighten the spring adjusting bolt "B" until the steering clutch hand lever remains in a partially disengaged position when pulled back and released.

3. Back off the spring adjusting bolt a turn at a time and manipulate the hand lever until it returns to the fully engaged position when released.

4. Tighten the lock nut "A."

5. Repeat this procedure for the other lever.

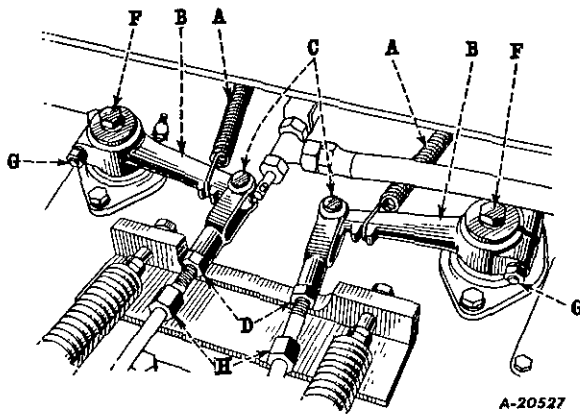

Illust. 49 - Adjustment Points for Steering Clutches.

Hand Lever Booster

Correct adjustment is obtained when the steering clutch hand levers can be pulled back with the minimum of effort and return to the fully engaged position when released. If the hand levers do not return to the fully engaged position when released, the booster spring tension is too great. If the levers remain in a partially disengaged position, undue wear of steering clutch discs will result. For best results we suggest the following procedure:

1. Loosen the spring adjusting bolt lock nut "A." (See Illust. 51.)

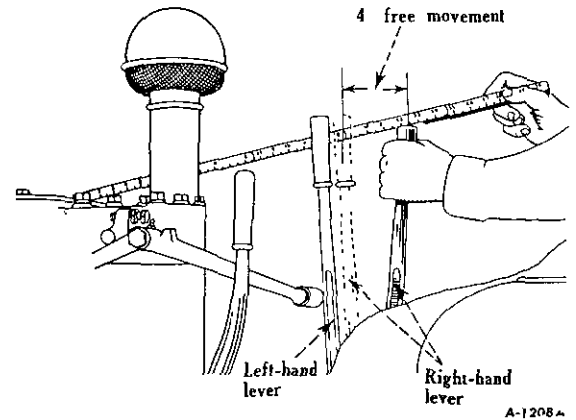

Illust. 50 - Measuring Free Movement of Steering Clutch Levers.

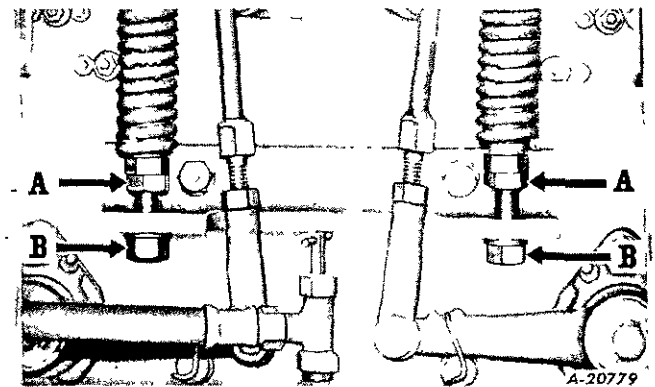

Illust. 51 - Hand Lever Booster Adjustment.



STEERING CLUTCH HYDRAULIC BOOSTER

16. DESCRIPTION

The hydraulic steering booster used on the 14, 15, 18 and 20 Series Crawler Tractors eliminates the effort of disengaging the steering clutches. The clutches are actuated by hydraulic oil flow through the booster, and controlled by two steering levers. By pulling one of the levers, the operator disengages that particular clutch and interrupts the flow of power to that track. Releasing the lever automatically returns the lever to the forward position and the clutch will engage.

The power to either or both tracks can be disengaged partially or fully with a slight pull on either lever.

The hydraulic pump used to supply oil pressure to the booster is a Webster - 2H2CS-2H2CS-1 (or Hydreco - 151010N18F1) positive displacement gear type, gear driven, dual pump. The pump operates continuously when the engine is running, but is under load only when the steering booster demands pressure. The outlet or pressure side of the pump is the side on which the gear teeth mesh. The inlet or suction side of the pump is the side on which the gear teeth unmesh. (See Illust. 52.)

As the pump is a dual type, there are two pressure lines, one to each cylinder of the booster and one return or suction line which returns the hydraulic oil back to the pump. (See Illust. 54.)

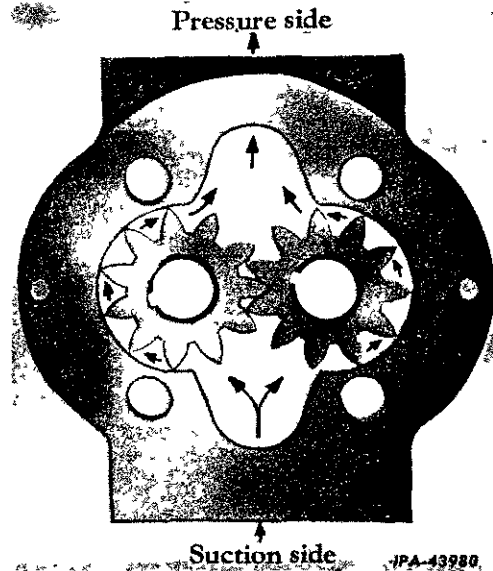

Illust. 52 - Oil Flow Through Hydraulic Pump (Viewed from Adapter End).

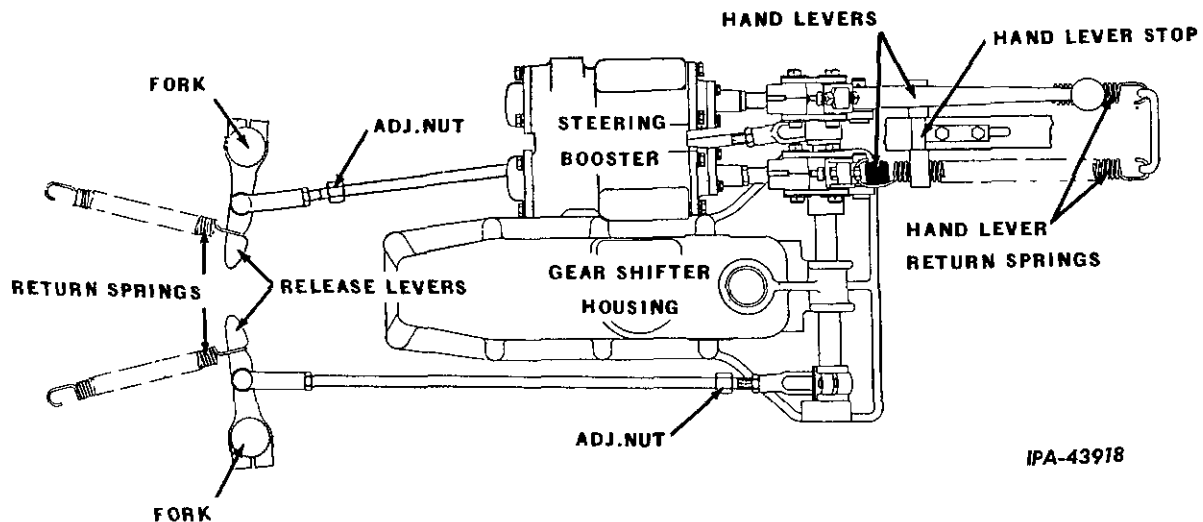

Illust. 53 - Hydraulic Steering Booster Controls.