



## 1. DESCRIPTION

The sprocket and sprocket drive assembly consists of a set of spur gears located in separate gear cases, one on each side at the rear of the tractor. Engine power is transmitted from the bevel drive gear through the steering clutches to the sprocket drives. The sprockets, which are attached to the sprocket drive gears, transmit power to the tracks.

Each sprocket drive consists mainly of a sprocket drive pinion, driven by a splined shaft (extending from the steering clutch), and a large sprocket drive gear (driven by the pinion) which, in turn, drives the sprocket. The

sprocket drives are completely enclosed in a gasket sealed compartment between the sprocket drive inner housing (or the sprocket drive carrier, on wide tread tractors) and the sprocket drive outer housing. The bearings are sealed with labyrinth bracket seals and two self adjusting, floating, diaphragm type seals.

The hub or sprocket carrier of each sprocket is splined to the hub of the sprocket drive gear and rotates on a ball bearing pressed on the track frame pivot shaft. Sprockets are reversible; they can be removed from their carriers, reversed, and placed on the same side of the tractor again. This makes it possible to use both sides of the sprocket teeth.

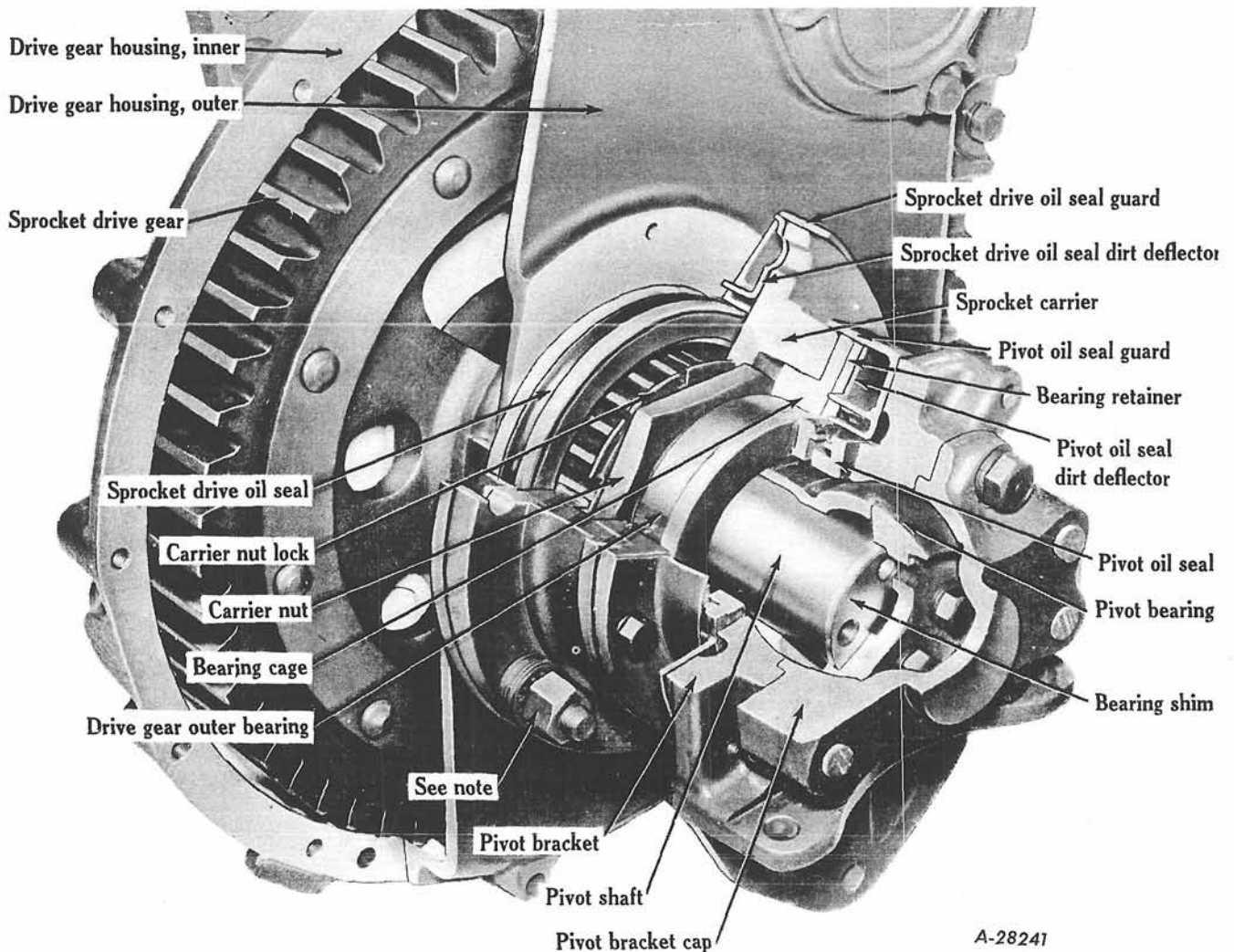

Illust. 1 - Cutaway View of Sprocket Drive.

NOTE: The sprocket is not shown above; if it were shown, it would be assembled under the nut indicated, against the sprocket carrier.



2. SPECIFICATIONS

	"6" Series (61 and 62)	"9" Series (91 and 92)
Number of teeth:		
Sprocket . . . . .	25	27
Sprocket drive pinion . . . . .	12	12
Sprocket drive gear . . . . .	51	57
Output reduction . . . . .	4.25 to 1	4.75 to 1
Tooth thickness at pitch circle (inches):		
Sprocket drive pinion . . . . .	.5164 - .5189	.5947 - .5972
Sprocket drive gear . . . . .	.3134 - .3158	.3610 - .3635
Backlash (inches) . . . . .	.013 - .018	.015 - .020
Bearings:		
Sprocket drive pinion shaft, inner . . . . .	roller	- - - -
Sprocket drive pinion shaft, outer . . . . .	roller	- - - -
Sprocket drive pinion, inner . . . . .	- - - -	ball
Sprocket drive pinion, outer . . . . .	- - - -	ball
Steering clutch support (wide tread) . . . . .	ball	ball
Sprocket drive gear, inner . . . . .	roller	roller
Sprocket drive gear, outer . . . . .	ball	ball
SPECIAL TORQUES * (Foot Pounds)		
Sprocket drive gear carrier nut . . . . .	630-700	630 - 700
Sprocket drive pinion bearing nuts . . . . .	50 - 60	- - - -
Sprocket drive pinion inner bearing nut . . . . .	175 -200	- - - -
Sprocket drive pinion bearing retainer cap screws . . . . .	- - - -	56 - 63
Sprocket drive pinion shaft bearing nuts (wide tread) . . . . .	280-320	280 - 320
Sprocket carrier (hub) bolt nuts . . . . .	125-140	170 - 190
Pivot bracket bolts, top . . . . .	130-145	250 - 290
Pivot bracket bolts, side . . . . .	250-290	280 - 320

\* All threads to be lubricated with SAE-30 engine oil.

3. CHECKING MECHANICAL PROBLEMS

PROBABLE CAUSE

REMEDY

SPROCKET DRIVES OVERHEATING

- |  |   |
|--|---|
| 1. Improper or insufficient lubrication. . . . . | Use proper grade and amount of lubricant. Check for leaks.                        |
| 2. Bearing seizure . . . . .                     | Remove the sprocket drive and inspect for damaged bearings. Replace if necessary. |

SPROCKET DRIVE GEAR NOISY

- |   |   |
|---|---|
| 1. Misaligned or damaged gears . . . . .              | Inspect the gears and replace if necessary. |
| 2. Improper, dirty or insufficient lubricant. . . . . | Use proper grade and amount of lubricant.   |

LUBRICANT LEAKAGE

- |                               |   |
|-------------------------------|---|
| 1. Faulty gasket. . . . .     | Oil leaks may occur at sprocket drive gear cover gasket or at other gaskets. Replace gaskets. |
| 2. Faulty oil seals . . . . . | Replace oil seals.  |



PROBABLE CAUSE

REMEDY

EXCESSIVE BACKLASH

- 1. Sprocket drive or pinion shaft worn or damaged. . . . . Replace worn or damaged parts.

EXCESSIVE WEAR ON SPROCKETS

- 1. Tracks run too loosely . . . . . Adjust the tracks. (See Section 9.)
- 2. Tracks worn excessively. . . . . Install new tracks. (See Section 9.)
- 3. Track frame out of alignment or damaged. . . . . Repair, or install new track frame. (See Section 9)

SPROCKET

4. REMOVAL

- 1. Take off the track chain, but do not remove it from under the tractor. Refer to "TRACKS AND TRACK FRAME," Section 9.
- 2. Disconnect the diagonal brace from the pivot shaft but not from the track frame. Refer to "TRACKS AND TRACK FRAME," Section 9.
- 3. Remove the sprocket shield and the pivot bracket cap and gasket. (Illust. 2.)
- 4. Disconnect the pivot bracket from the track frame by removing the top and side bolts, (Illust. 3) and lay the track frame clear.

- 5. Raise the rear of tractor high enough so that the sprocket will clear the track frame. Block the tractor securely.

- 6. Remove the cap screws securing the pivot bearing to the pivot shaft, (Illust. 4). Remove the pivot bracket assembly together with the pivot bearing, (Illust. 5). Remove the oil seal should it remain on pivot shaft.

- 7. Remove the nuts and washers which secure the sprocket to the sprocket carrier or hub. Remove the sprocket from the carrier, (Illust. 6). If necessary, break the sprocket loose

continued on next page

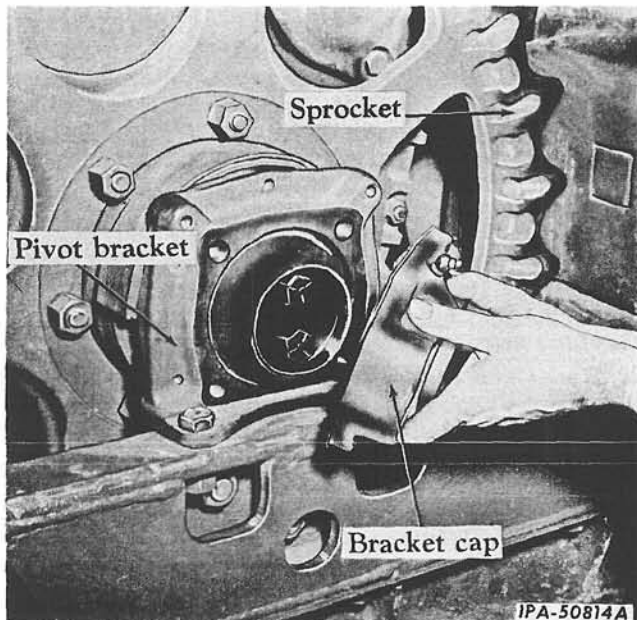

Illust. 2 - Removing Pivot Bracket Cap.

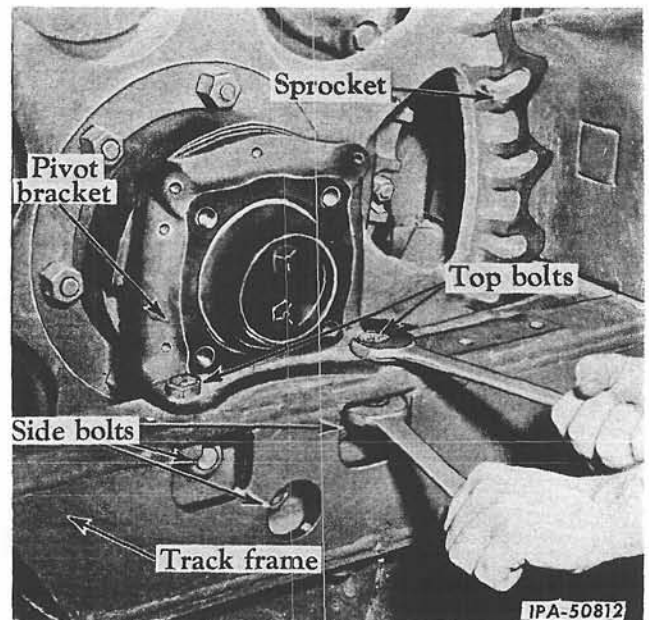

Illust. 3 - Removing Pivot Bracket.



## SPROCKET

## 4. REMOVAL - Continued

from the carrier with a sledge hammer or a large three-jaw puller.

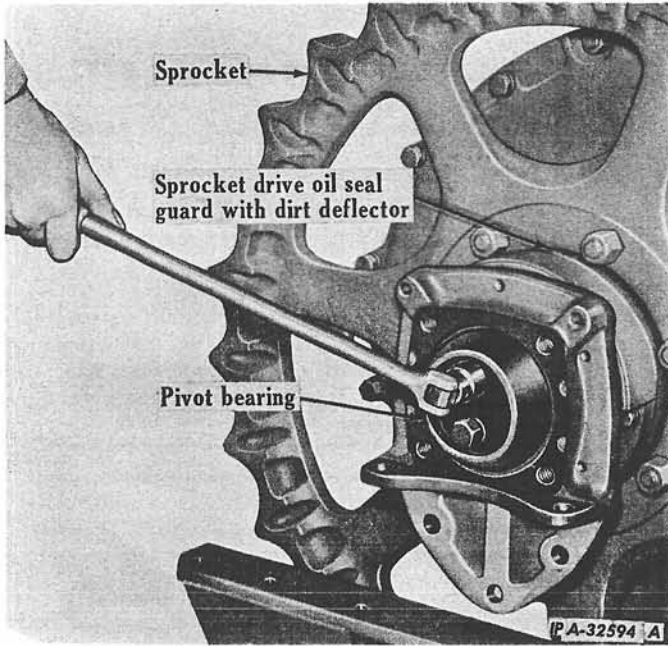

Illust. 4 - Removing Pivot Bearing.

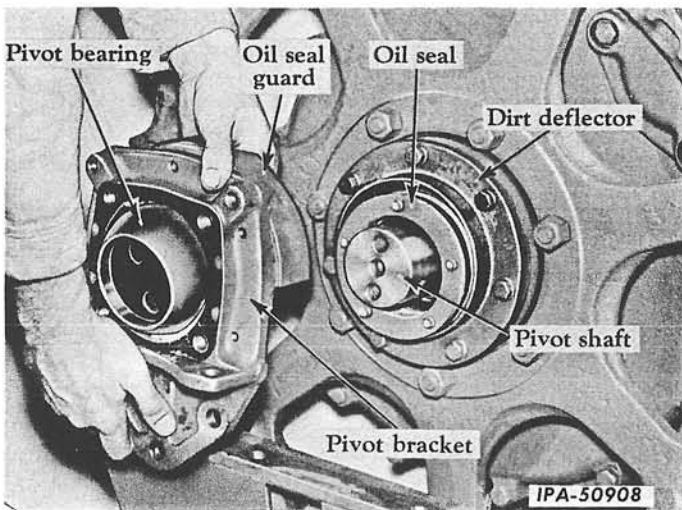

Illust. 5 - Removing Pivot Bracket Assembly.

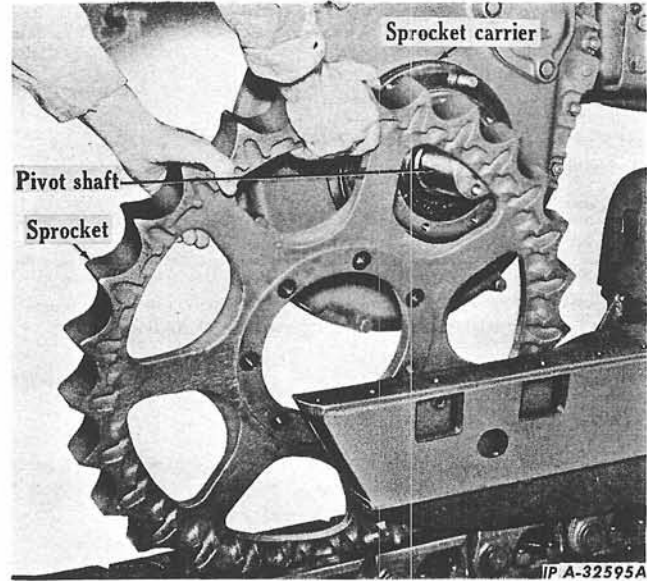

Illust. 6 - Removing Sprocket.

## 5. INSPECTION AND REPAIR

**SPROCKET:** Examine the sprocket for wear. Excessive wear is indicated if the sprocket jumps the track chain when the track adjustment is correct. A worn sprocket (if worn on one side of the teeth only) may be reversed and reinstalled on the same side of the tractor.

## Pivot Bracket Assembly

1. Remove the pivot bearing from the pivot bracket, and the oil seal from the inner side of the pivot bracket if the oil seal remained in the bracket during bracket removal. Remove the shims from inside the pivot bearing and keep them for use in reassembly.
2. Clean and inspect the pivot bearing surfaces of the bracket, cap and bearing for scoring; cracks, or excessive wear. (Illust. 7.) Clean the grease fitting and passage through the bracket cap to assure dirt free lubrication. Replace parts as necessary.
3. Clean and inspect the inner or oil seal guard side of the pivot bracket. (Illust. 8.) See that the oil seal peg holes are thoroughly clean to assure even seating of the oil seal.
4. Examine the diaphragm type oil seal to be sure that it is fit for service. The diaphragm must be free of cracks or general deterioration. The sealing washer should protrude from the seal to prevent metal to metal contact with the bearing retainer. The friction or sealing surface of this washer should be free of glaze and high spots for good sealing. Compress the



SPROCKET

seal to make sure that the inner springs expand it evenly to its free width and that no springs are broken. Replace the entire oil seal with a new one if examination indicates any part not fit for service.

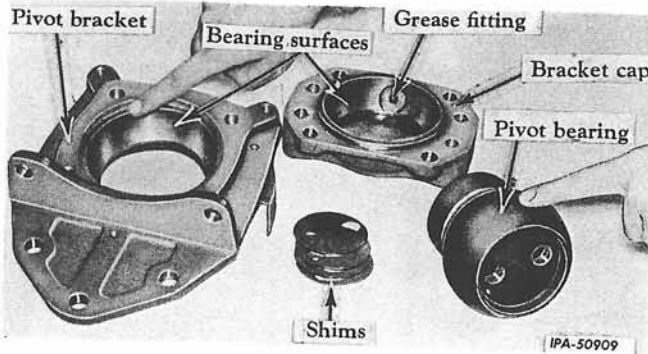

Illust. 7 - Pivot Bracket Assembly (Outer Side).

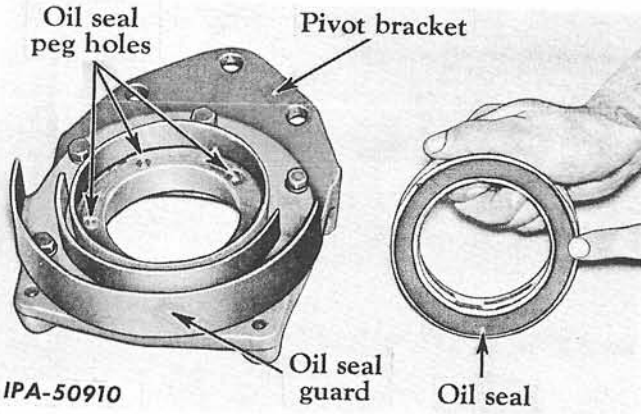

Illust. 8 - Pivot Bracket Assembly (Inner Side).

6. INSTALLATION

1. Lift the sprocket into position, lining up the holes in the sprocket with the cap screws projecting from the sprocket carrier or hub. Fasten the sprocket to the carrier with nuts and lock washers. Torque the nuts as given in Par. 2, "SPECIFICATIONS."
2. Assemble a new gasket (57, Illust. 11 or 58, Illust. 12) to the peg side of oil seal (56 or 57). Dip the sealing washer surface in oil, and insert the peg side of the seal into the pivot bracket (59 or 60), so that the pegs set in the holes of bracket, and place the pivot bracket complete with the oil seal guard and oil seal onto the pivot shaft.

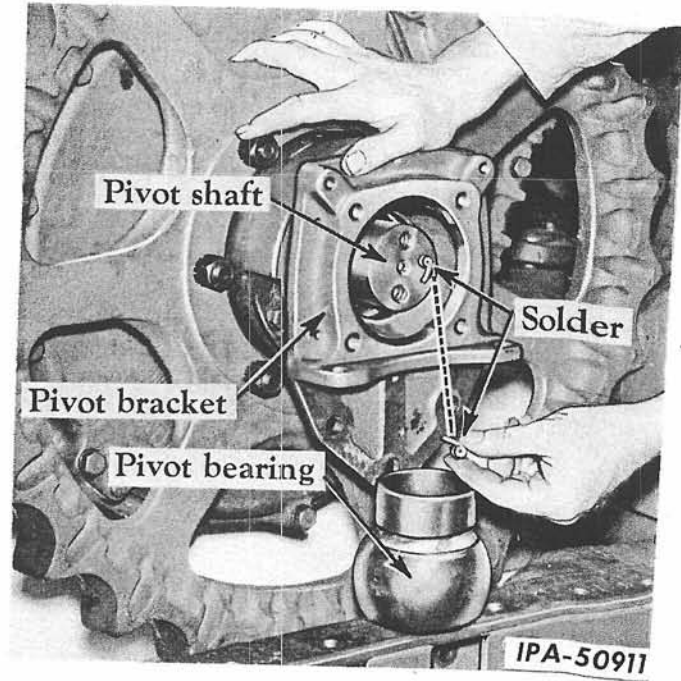

Illust. 9 - Install Measuring Material.

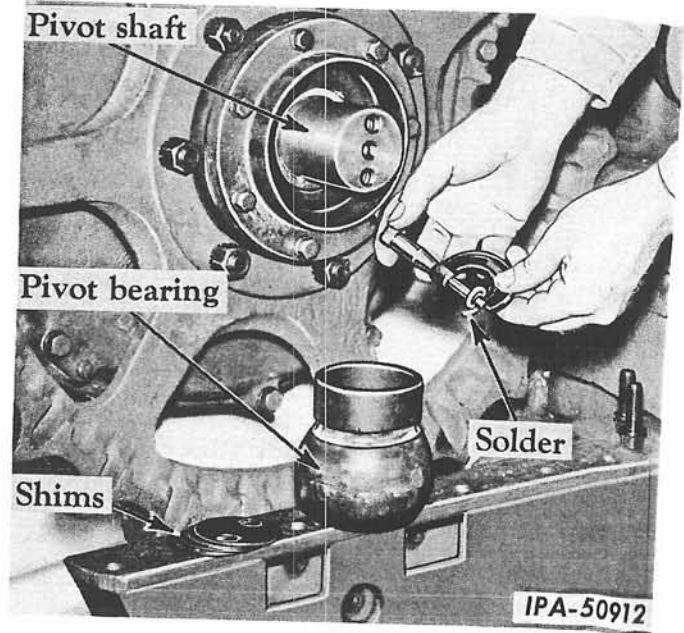

Illust. 10 - Measuring for Shim Thickness.

continued on page 8



SPROCKET

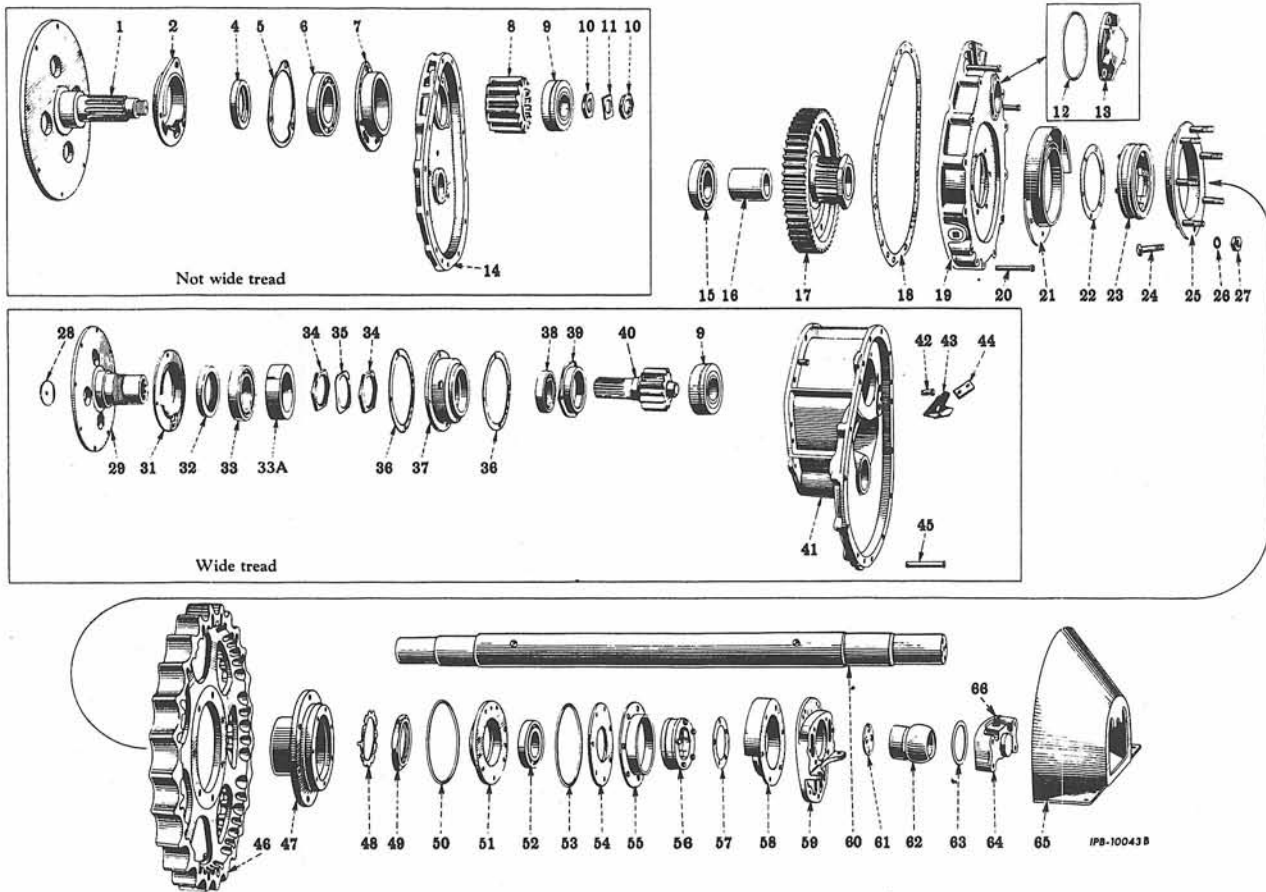

Illust. 11 - Exploded View of Sprocket and Sprocket Drive (6, 6(61) and 6(62) Series).

- |                                |   |   |                                    |
|--------------------------------|---|---|------------------------------------|
| 1. Pinion shaft.               | 17. Drive gear.                           | 34. Retainer nut.                               | 49. Nut.                           |
| 2. Bearing retainer.           | 18. Gasket.                               | 35. Nut lock.                                   | 50. "O" ring (outer).              |
| 4. Oil seal.                   | 19. Outer housing.                        | 36. Gasket.                                     | 51. Bearing cage.                  |
| 5. Gasket.                     | 20. Dowel pin.                            | 37. Bearing cage.                               | 52. Drive gear outer ball bearing. |
| *6. Pinion inner bearing.      | 21. Oil seal guard.                       | *38. Pinion inner bearing.                      | 53. "O" ring (inner).              |
| 7. Bearing cage.               | 22. Gasket.                               | 39. Bearing cage.                               | 54. Bearing retainer.              |
| 8. Sprocket drive pinion.      | 23. Oil seal.                             | 40. Sprocket drive pinion.                      | 55. Dirt deflector.                |
| *9. Pinion outer bearing.      | 24. Bolt.                                 | 41. Sprocket drive carrier.                     | 56. Oil seal.                      |
| 10. Retainer nut.              | 25. Dirt deflector.                       | 42. Upper dowel pin.                            | 57. Gasket.                        |
| 11. Nut lock.                  | 26. Lock washer.                          | 43. Steering clutch support bearing oil trough. | 58. Oil seal guard.                |
| 12. Cap "O" ring.              | 27. Nut.                                  | 44. Trough lock.                                | 59. Pivot bracket.                 |
| 13. Outer bearing cap.         | 28. Expansion plug.                       | 45. Lower dowel pin.                            | 60. Pivot shaft.                   |
| 14. Inner housing.             | 29. Pinion shaft.                         | 46. Sprocket.                                   | 61. Bearing shim.                  |
| *15. Drive gear inner bearing. | 30. Oil seal.                             | 47. Sprocket carrier.                           | 62. Pivot bearing.                 |
| 16. Bearing spacer.            | 31. Bearing retainer.                     | 48. Nut lock.                                   | 63. Gasket.                        |
|                                | 32. Oil seal.                             |   | 64. Bracket cap.                   |
|                                | 33. Steering clutch support ball bearing. |   | 65. Sprocket shield.               |
|                                | 33A. Bearing nut spacer (62 only).        |   | 66. Pivot lubricator.              |

\*Ball bearings used in older "6" series. Latest 6, 6 (61) and 6 (62) series use separable straight roller type bearings. Replace bearings, when necessary, with the same type found in the assembly. DO NOT SUBSTITUTE.



SPROCKET

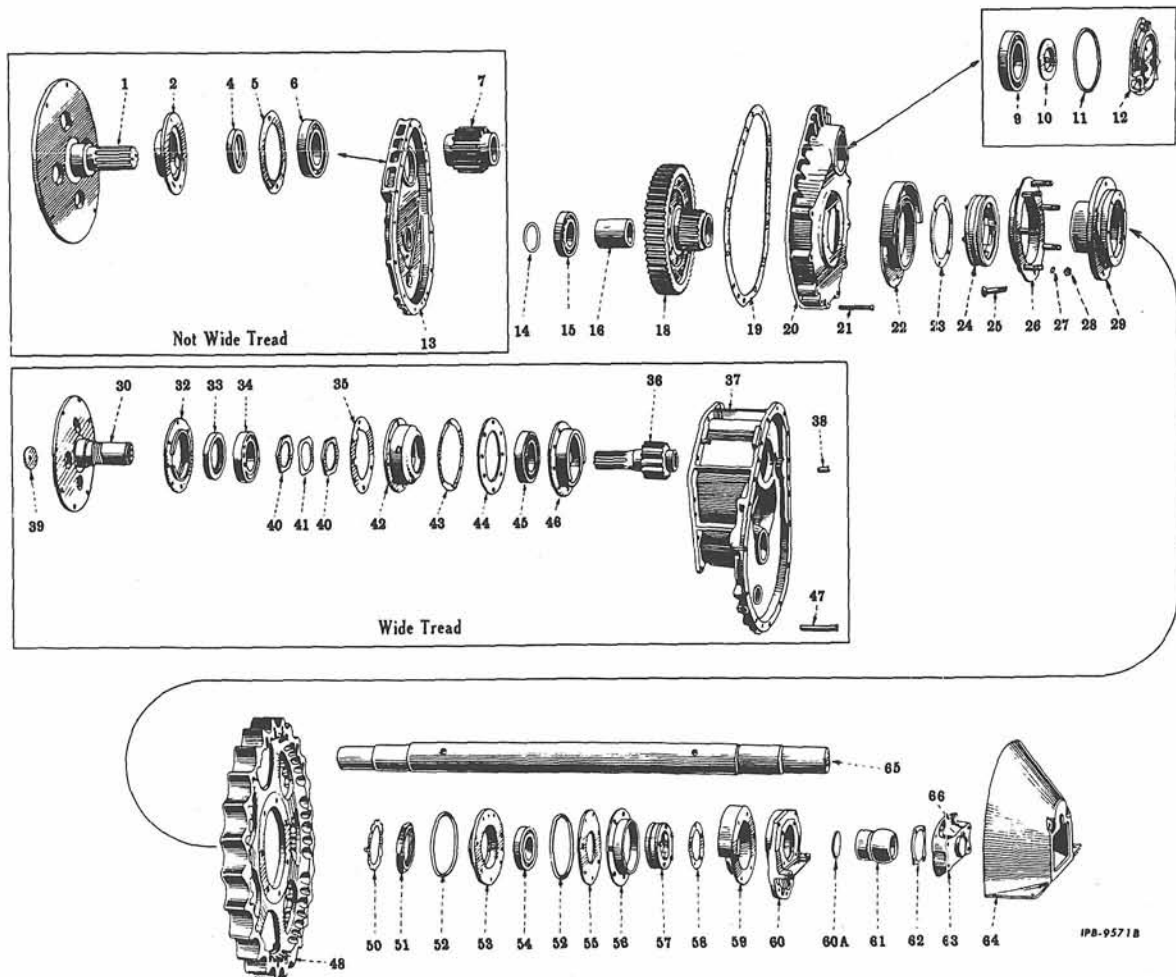

Illust. 12 - Exploded View of Sprocket and Sprocket Drive (9, 9(91) and 9(92) Series).

- |                       |                       |                       |                       |
|-----------------------|-----------------------|-----------------------|-----------------------|
| 1. Pinion shaft.      | 16. Bearing spacer.   | 35. Gasket.           | 51. Nut.              |
| 2. Bearing retainer.  | 18. Drive gear.       | 36. Sprocket drive    | 52. "O" ring.         |
| 3. Felt washer.       | 19. Gasket.           | pinion.               | 53. Bearing cage.     |
| 4. Oil seal.          | 20. Outer housing.    | 37. Sprocket drive    | 54. Drive gear outer  |
| 5. Gasket.            | 21. Lower dowel pin.  | carrier.              | ball bearing.         |
| 6. Pinion inner       | 22. Oil seal guard.   | 38. Upper dowel pin.  | 55. Bearing retainer. |
| ball bearing.         | 23. Snap-on gasket.   | 39. Expansion plug.   | 56. Dirt deflector.   |
| 7. Sprocket drive     | 24. Oil seal.         | 40. Bearing nut.      | 57. Oil seal.         |
| pinion.               | 25. Bolt.             | 41. Nut lock.         | 58. Snap-on gasket.   |
| 8. Upper dowel pin.   | 26. Dirt deflector.   | 42. Bearing cage.     | 59. Oil seal guard.   |
| 9. Pinion outer       | 27. Lock washer.      | 43. Gasket.           | 60. Pivot bracket.    |
| ball bearing.         | 28. Nut.              | 44. Bearing retainer. | 60A. Bearing shim.    |
| 10. Bearing retainer. | 29. Sprocket carrier. | 45. Pinion inner      | 61. Pivot bearing.    |
| 11. Cap "O" ring.     | 30. Pinion shaft.     | ball bearing.         | 62. Gasket.           |
| 12. Outer bearing     | 32. Bearing retainer. | 46. Bearing cage.     | 63. Bracket cap.      |
| cap.                  | 33. Oil seal.         | 47. Lower dowel pin.  | 64. Sprocket shield.  |
| 13. Inner housing.    | 34. Steering clutch   | 48. Sprocket.         | 65. Pinion shaft.     |
| 14. Oil seal ring.    | support ball          | 50. Nut lock.         | 66. Pivot lubricator. |
| 15. Drive gear inner  | bearing.              |                       |                       |
| bearing.              |                       |                       |                       |



## SPROCKET

## 6. INSTALLATION - Continued

3. Install the pivot bearing (61 or 62) (less the shims) and tighten the pivot bearing cap screws to final specified torque as required per diameter and type of cap screw. (Refer to "STANDARD TORQUE DATA" in Section 1.) This will take up the clearance between the bearings and the spacer.

4. Remove the pivot bearing and place a ball of molding clay, putty, or solder (about 1/4 inch round) on the pivot shaft (Illust. 9). Install the pivot bearing and torque the cap screws to 50 foot pounds.

5. Remove the pivot bearing and carefully remove the compressed material from the pivot shaft. Measure the thickness with a micrometer. This measurement, less .013 to .018 inch, represents the thickness in shims to be installed to properly pre-load the pivot bearing.

6. Install the shims and torque the cap screws to final specified torque as required per diameter and type of cap screw. (Refer to "STANDARD TORQUE DATA" in Section 1.)

7. Lower the tractor onto the tracks and assemble the track frame to the pivot bracket. Secure the pivot bracket to the track frame with the top and side bolts. Tighten the bolts to the torques shown under Par. 2, "SPECIFICATIONS."

8. Install the pivot bracket cap with a new gasket.

9. Connect the diagonal brace to the pivot shaft, being sure the correct bearing clearance is maintained. Refer to Section 9, "TRACKS AND TRACK FRAME."

10. Install and adjust the track chain. Refer to Section 9, "TRACKS AND TRACK FRAME."

## SPROCKET DRIVE

## 7. REMOVAL AND DISASSEMBLY

## Regular Tread

1. Remove the sprocket as outlined in Par. 4.
2. Drain the lubricant from the sprocket drive.
3. Remove the pivot oil seal dirt deflector and the drive gear outer bearing retainer (Illust. 13), by removing the seven cap screws that secure them and the outer bearing cage to the sprocket carrier.
4. Pull the drive gear outer bearing and cage by installing jack screws in the flange of the cage (Illust. 14), and draw up on them evenly. If necessary to replace the bearing, it can be pulled or driven from the cage. It is not necessary to remove the "O" ring around the outer circumference of the bearing unless the bearing is to be removed.
5. Straighten the lips of the nut lock and remove the sprocket drive gear carrier nut, using special socket wrench SE-1184-1, (Illust. 15). Refer to "Service Tools" manual ISS-1002.
6. Remove the sprocket carrier from the drive gear carrier splines (Illust. 16).
7. Remove the pinion outer bearing cap and seal ring (Illust. 15).

ISS-1032B (6-64)

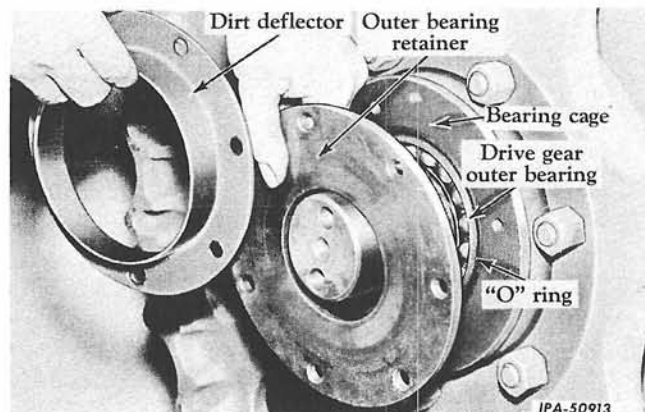

Illust. 13 - Removing Dirt Deflector and Outer Bearing Retainer.

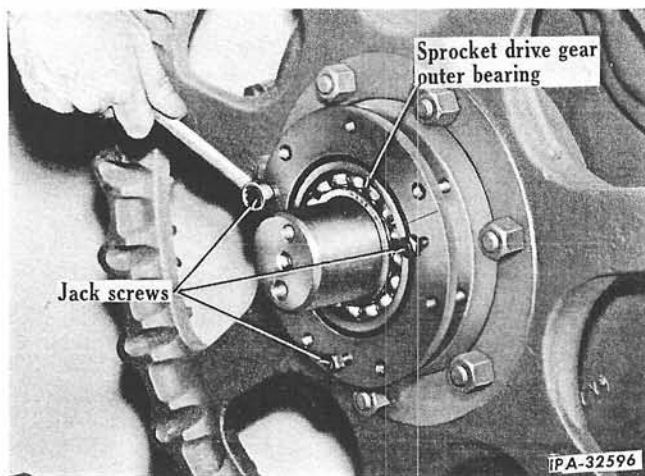

Illust. 14 - Removing Outer Bearing and Cage.





SPROCKET DRIVE

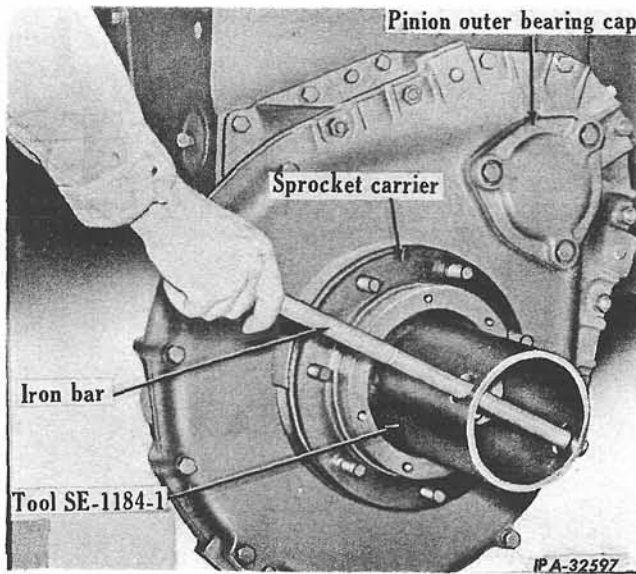

Illust. 15 - Removing Sprocket Carrier Nut.

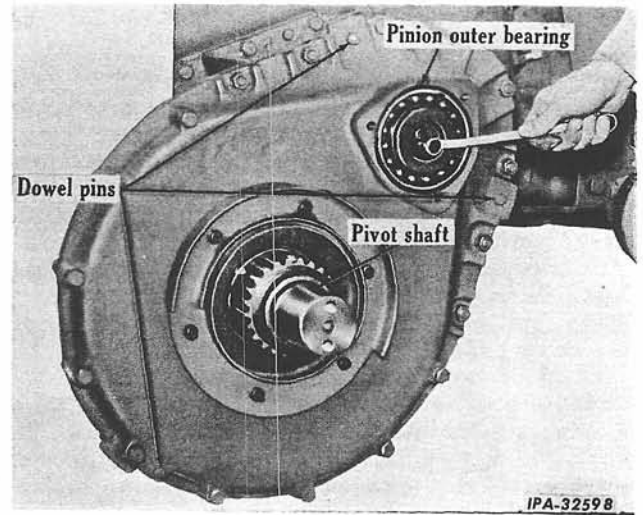

Illust. 17 - Removing Pinion Outer Bearing Washer ("9" Series).

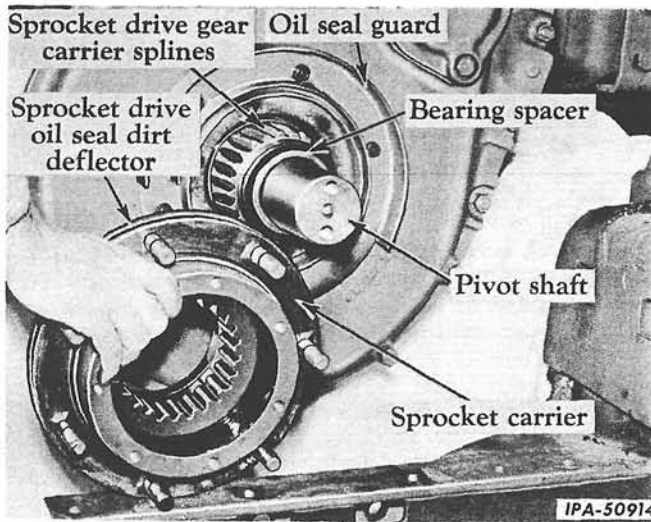

Illust. 16 - Removing Sprocket Carrier.

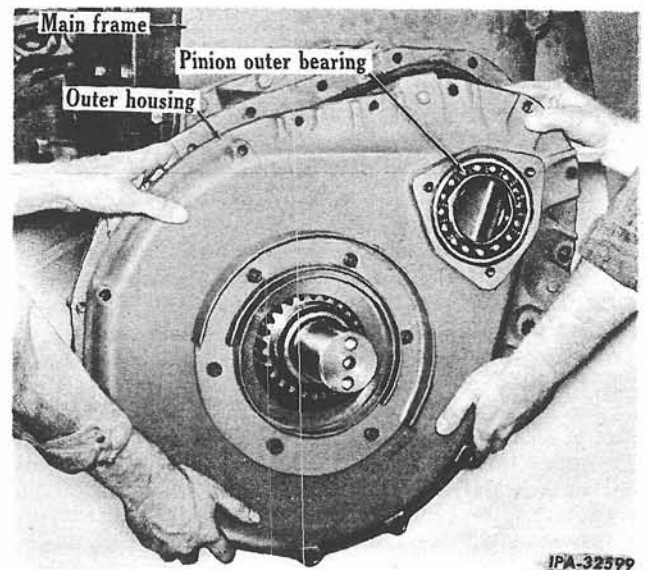

Illust. 18 - Removing Sprocket Drive Gear Outer Housing ("9" Series).

8. 6, 6(61) and 6 (62) SERIES: Straighten the lips of nut lock, and remove the lock nut and the outer bearing retaining nut from the end of sprocket drive pinion shaft (1, Illust. 11).

9. 9 (91) AND 9 (92) SERIES: Remove the two cap screws, lock washers and the outer bearing retainer (Illust. 17).

9. Remove all the cap screws and nuts securing the outer housing to the inner housing and,

using three jack screws, separate the housings. The housings are aligned with dowel pins, therefore the jack screws must be tightened down evenly. Slide and lift the outer housing away from the inner housing (Illust. 18).

continued on next page



SPROCKET DRIVE

7. REMOVAL AND DISASSEMBLY - Continued

Regular Tread - Continued

10. Remove the sprocket drive gear and pinion (Illust. 19), and slide the bearing spacer (16, Illust. 11 or 12) off the pivot shaft. On tractors equipped with roller bearings, first remove the inner race of the pinion outer bearing from the end of pinion shaft then, simply pull the drive gear and pinion away from the inner housing to separate the inner bearing races. Tractors having ball bearings require a puller to remove the drive gear with inner bearing from the pivot shaft, and again to pull the pinion shoulder from the inner bearing until the pinion is free to slide off the pinion shaft spline. The older "6" Series have a pinion roller type outer bearing, but a pinion inner ball bearing that requires a puller to remove the pinion.

NOTE: If necessary to remove the roller bearing outer race (late 6 and 6 (61) and 6 (62) series) or the ball bearing (early 6 and 9, 9 (91) and 9 (92) series) from the drive gear, tap out with the aid of a drift punch inserted through the three holes around the hub or gear carrier spline.

11. To remove the sprocket drive inner housing, first remove the steering brake inspection cover from the under side of the main frame, and place a jack under the steering clutch to support the weight of the clutch. Then remove the cap screws and nuts that secure the inner housing to the main frame. Pry the inner housing away from the main frame a little at a time and evenly to prevent binding around the pinion shaft and the pivot shaft. The pinion inner bearing assembly remains with inner housing during removal.

12. Remove the cap screws that secure pinion inner bearing retainer to the inner housing, and remove the retainer (2), oil seal (4), gasket (5), bearing (6) and bearing cage (7), Illust. 11, or the same parts covered by references (2 to 5, Illust. 12). If necessary to remove bearing (6) from 9, 9 (91) and 9 (92) series, it must be pressed from the bore of inner housing.

13. If the pinion shaft is to be removed, it will be necessary to remove the steering clutch. Refer to "STEERING CLUTCHES AND BRAKES," Section 7.

14. After the steering clutch has been removed, the pinion shaft can be removed through the steering clutch chamber, similar to Illust. 23, for the wide tread. The bearing assembly for regular tread remains attached to the inner

housing and is disassembled as outlined in above step 12.

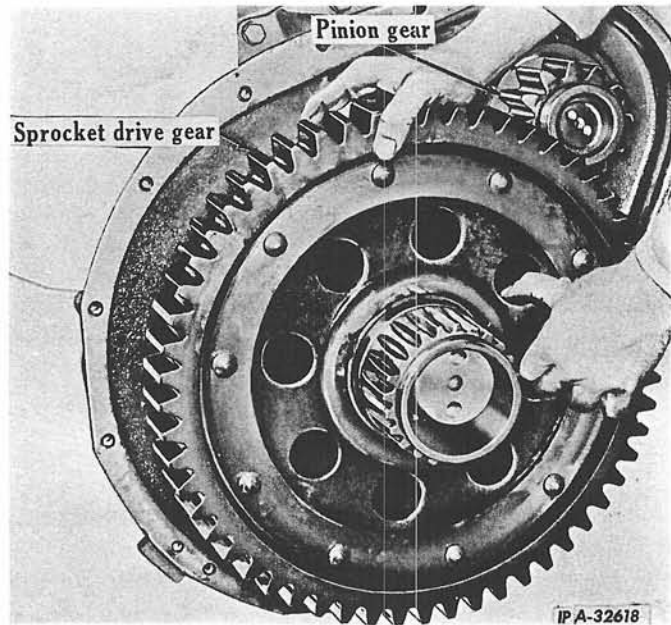

Illust. 19 - Removing Sprocket Drive Gear (9 Series shown).

8. REMOVAL AND DISASSEMBLY

Wide Tread

Removal of the sprocket drive for wide tread tractors is the same as for the regular tread as outlined in the preceding paragraph 7, up to and including step 7, then proceed as follows:

1. 6 SERIES: Straighten the lips of nut lock and remove the lock nut and the outer bearing retaining nut from the threaded end of the sprocket drive pinion (40, Illust. 11).

9 SERIES: Remove the two cap screws and lock washers (Illust. 17), securing the outer bearing retainer (10) to the end of the sprocket drive pinion (36, Illust. 12), and remove the outer bearing retainer.

2. Remove all cap screws and nuts securing the outer housing (19, Illust. 11; 20, Illust. 12) to the sprocket drive carrier (41 or 37, Illust. 11 or 12), see Illust. 20. Use three jack screws to separate the outer housing from the sprocket drive carrier. These two sections are aligned with dowel pins, therefore the jack screws must be tightened down evenly. Slide and lift the outer housing away from the sprocket drive carrier similar to Illust. 18.



## SPROCKET DRIVE

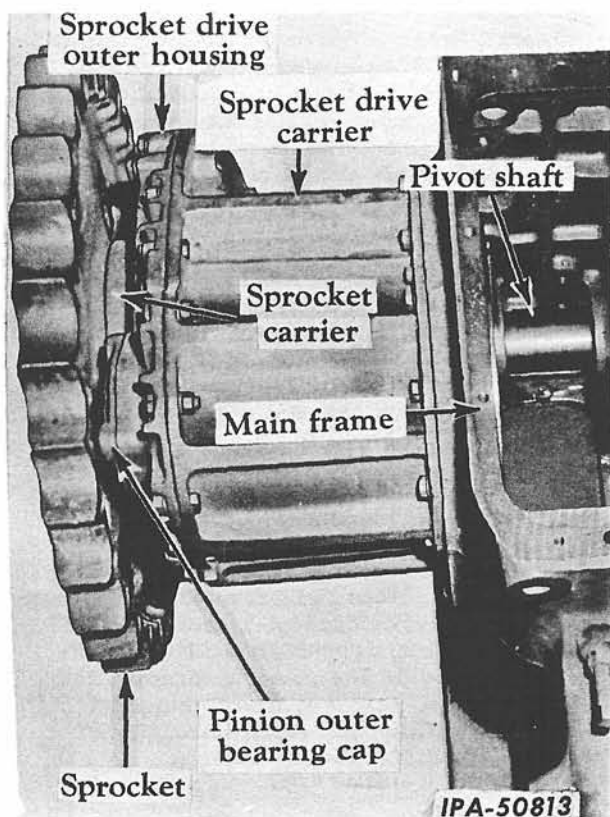

Illust. 20 - Sprocket and Sprocket Drive Carrier (Wide Tread).

3. Remove the sprocket drive gear (Illust. 19), and slide the bearing spacer (16, Illust. 11 or 12), off the pivot shaft.

LATER 6 AND 6 (61) SERIES are equipped with drive gear roller type inner bearings. Simply pull the drive gear away from the sprocket drive carrier to separate the inner and outer races, and remove the drive gear with outer race from the pivot shaft.

6 (62) SERIES: The drive gear is equipped with straight roller type inner bearings. Pull the drive gear away from the sprocket drive carrier (41) to separate the inner and outer races, and remove the drive gear with outer race from the pivot shaft, Illust. 19. If necessary to remove the outer race of the roller bearing from the bore of drive gear (17), weld a bead around the inner surface of the race and this will shrink the race enough for removal.

9, 9 (91), 9 (92) AND OLDER 6 SERIES are equipped with drive gear inner ball bearings. The use of a puller is required to remove the

inner ball bearing with the drive gear from the pivot shaft.

If necessary to remove the outer race of roller bearing 6, 6 (61) or the ball bearing 9 (91), 9 (92) and old 6 series from the drive gear, tap out with the aid of a drift punch inserted through the three holes around the hub of gear carrier spline.

4. Remove the sprocket drive pinion shown in Illust. 19, (40, Illust. 11 or 36, Illust. 12).

OLDER 6 SERIES: Before attempting to remove the pinion it will be necessary to remove the sprocket drive carrier from the main frame to gain access of the pinion inner bearing retaining nuts. This also applies for pinion inner ball bearing removal. Refer to Steps 5 and 6 for sprocket drive carrier removal.

LATER 6 and 6 (61) SERIES are equipped with pinion roller type inner bearings. Simply pull the pinion away from the sprocket drive carrier to separate the inner race from the outer race, also the pinion and pinion shaft splines. The outer race will remain in its bearing cage attached to the inside of the sprocket drive carrier. If necessary, the outer race can be pulled outward from the bearing cage. However, if the sprocket drive carrier is to be removed, the outer race may be tapped out of the bearing cage at this time, or pressed out if the bearing cage is removed from the inside of sprocket drive carrier.

6 (62) SERIES: Remove the sprocket drive pinion (40). The outer bearing (9) and inner bearing (38) are both straight roller type. Pull the pinion away from the sprocket drive carrier (41). The inner races of both bearings will stay with the pinion and can be removed with a puller if necessary.

The outer race of the inner bearing will remain in the bearing cage (39), attached to the inside of the sprocket drive carrier.

9, 9 (91) AND 9 (92) SERIES: The pinion may be pried or pulled from the inner ball bearing. The inner ball bearing will remain in its bearing cage which is secured to the inside of the sprocket drive carrier. If bearing replacement is necessary, the sprocket drive carrier must be removed to gain access to the retainer cap screws. Refer to Steps 5 and 6 for sprocket drive carrier removal.

Continued on Next Page



## SPROCKET DRIVE

## 8. REMOVAL AND DISASSEMBLY

Wide Tread - Continued

5. Further disassembly of the sprocket drive, before removing the sprocket drive carrier and/or the pinion shaft, requires the removal of the steering clutch. Refer to "STEERING CLUTCHES AND BRAKES," Section 7. With the steering clutch removed, remove the cap screws securing the steering clutch support bearing retainer and bearing cage to the sprocket drive carrier (Illust. 21). Rotate the pinion shaft flange to make the lower cap screws accessible.

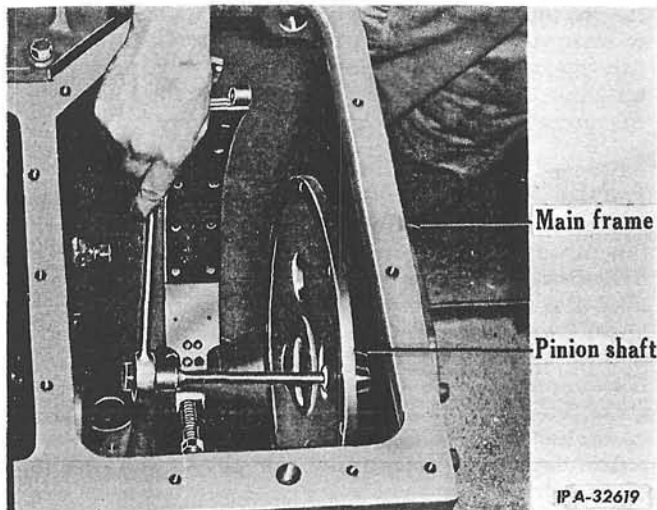

Illust. 21 - Removing Steering Clutch Support Bearing Cage Cap Screws (Wide Tread).

6. 6, 6 (61), 9, 9 (91) AND 9 (92) SERIES: Remove the nuts and cap screws securing the sprocket drive carrier to the main frame. Be sure to remove the cap screws between the webs on the inside of the carrier. Use jack screws to separate the sprocket drive carrier from the main frame or pry the carrier away from main frame, as may be the case, and move the carrier, carefully straight off the pivot shaft to prevent binding (Illust. 22).

6 (62) SERIES: Remove the sprocket drive carrier (41) from the main frame as outlined in the following Steps A to D, to have access to the steering clutch support bearing assembly, Illust. 23.

(a) Remove the outer race of pinion gear inner bearing (38) from the bearing cage (39), using a bearing puller for this purpose.

(b) Insert a wrench through the opening in bearing cage (39) and remove all the cap screws and lock washers securing the bearing cage to the inner wall of the sprocket drive carrier. Tap the bearing cage from the bore and lower the bearing cage to the bottom of the sprocket drive carrier.

(c) Insert a drift or screwdriver through the opening and bend back the lug or nut lock (35). Then remove the retainer nuts (34) from the pinion shaft (29) with a 3-1/2-inch socket head wrench. Remove the spacer (33A) from the end of pinion shaft (29).

(d) Remove the nuts and cap screws securing the sprocket drive carrier (41) to the main frame. Be sure to remove the cap screws between the webs on the inside of the carrier. Use jack screws to separate the sprocket drive carrier from the main frame or pry the carrier away from main frame, as may be the case, and move the carrier and the steering clutch support bearing assembly, carefully straight off the pivot shaft to prevent binding.

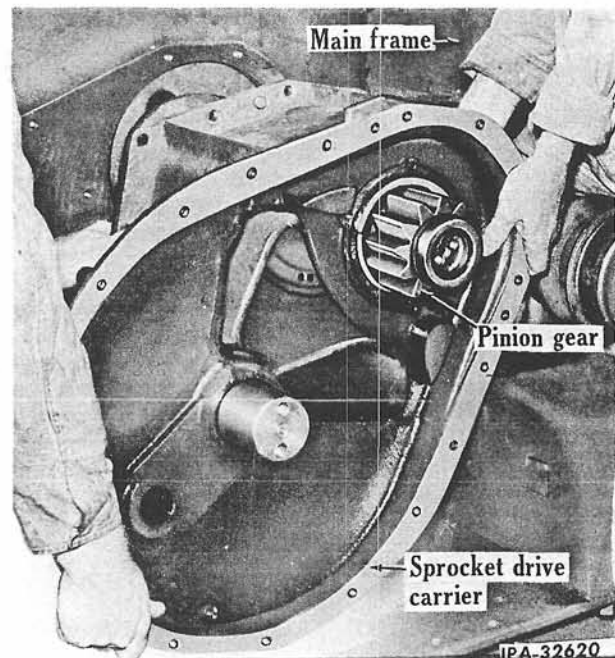

Illust. 22 - Removing Sprocket Drive Carrier (Wide Tread).



## SPROCKET DRIVE

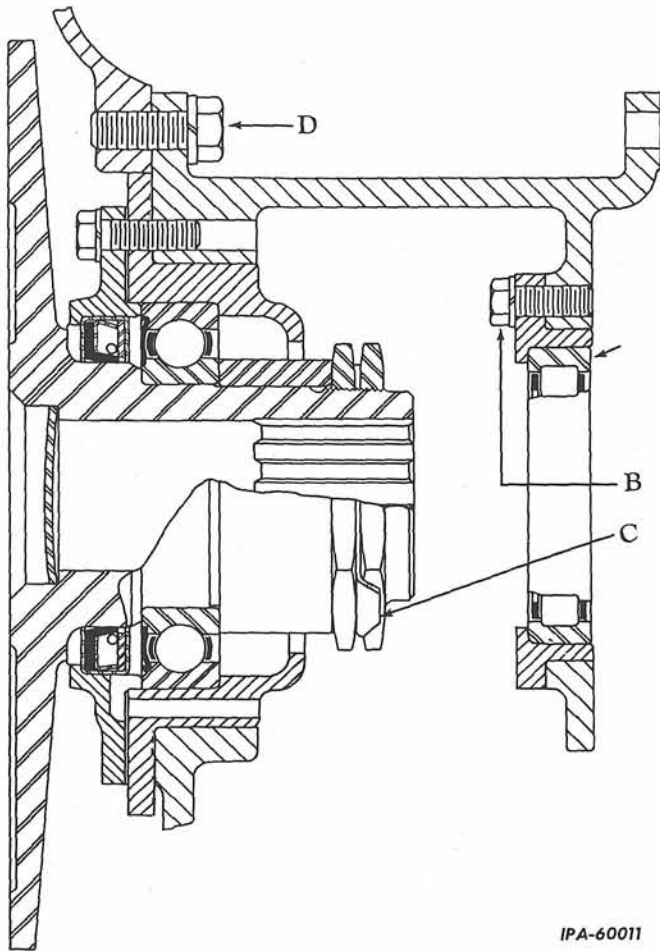

IPA-60011

Illust. 23 - Steering Clutch Pinion Shaft and Support Bearing Assembly Sectional View TD-6 (62) Series (Wide Tread).

7. 6, 6 (61), 9, 9 (91) AND 9 (92) SERIES: The pinion inner bearing assembly can be removed from the inside of the sprocket drive carrier by removing the cap screws that secure the bearing cage to the carrier. On the older "6" Series the pinion is removed with the inner bearing assembly through the inside of the carrier. To remove this pinion from the bearing assembly, straighten the lips of nut lock, remove the lock nut, and bearing retaining nut, then press or pull the pinion from the bearing assembly.

6 (62) SERIES: Remove and disassemble the steering clutch support bearing assembly from the sprocket drive carrier. Remove the cap

screws securing the bearing retainer and bearing cage (31 and 32) to the drive carrier (41). Remove the bearing retainer (31) with oil seal (32), and the gasket (36) from the bearing cage (37). Separate the bearing cage (37) with ball bearing (33), from the drive carrier. Remove the pinion gear inner bearing cage (39) lying loose in the bottom of the drive carrier housing.

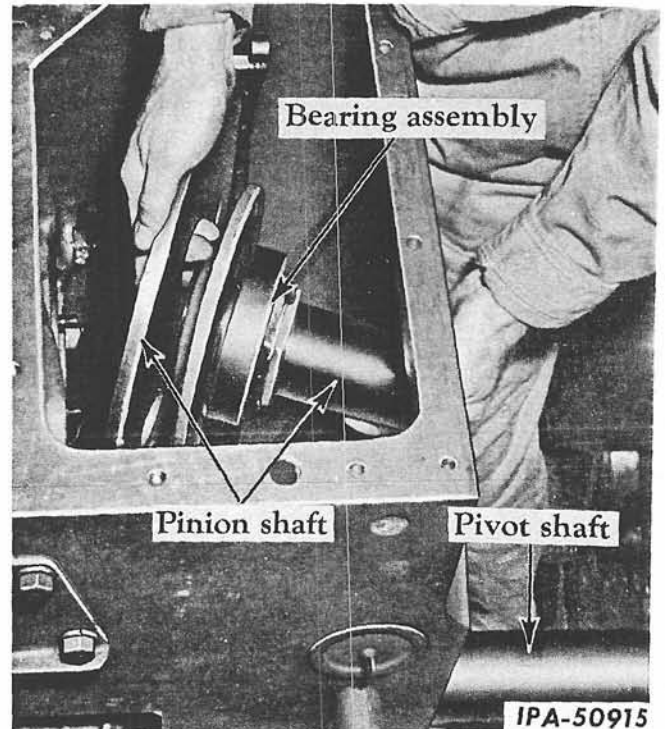

Illust. 24 - Removing Pinion Shaft and Bearing Assembly (Wide Tread).

8. Remove the pinion shaft and the steering clutch support bearing assembly through the steering clutch compartment (Illust. 24).

9. To disassemble the pinion shaft (Illust. 25) pry off the bearing cage and remove the gasket. Straighten the lips of nut lock, remove the lock nut and the bearing nut. Remove the bearing and bearing retainer with oil seal, from the pinion shaft. Pull the oil seal from bearing retainer.



## SPROCKET DRIVE

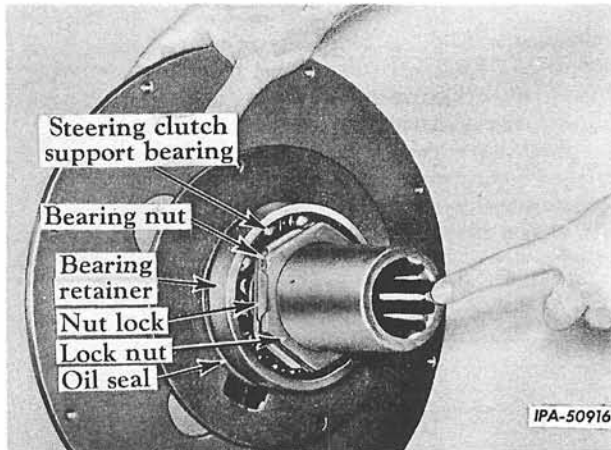

Illust. 25 - Disassembling Pinion Shaft Bearing Assembly (Wide Tread).

## 9. INSPECTION AND REPAIR

1. Inspect the oil seal for the pinion shaft assembly (Illust. 24), and if worn, press in a new oil soaked seal so the lips will face the bearing. Replace the bearing if necessary. Reassemble the bearing assembly to the inner housing for regular tread, but onto the pinion shaft for the wide tread. Refer to Par. 10 and 11.

2. Inspect the sprocket teeth for excessive wear which will cause the sprocket to jump the track chain even with proper track tension. If the teeth are worn on one side only, the sprocket may be reversed to place the unworn side of the teeth to the track chain bushings.

3. Inspect the bearings for scores, cracks, checks, wear and looseness in their cages or supports. Replace those that are not fit for further use. Oil those that are in serviceable condition and wrap or cover them until ready for assembly.

4. Inspect bearing surfaces of pivot bracket, cap, and pivot bearing for scoring, cracks, or excessive wear, also the oil seal, Illust. 7 and 8. Replace parts as necessary.

5. Inspect the sprocket drive gear and pinion gear for worn, chipped, or broken teeth or splines (Illust. 26). If one side of the teeth is worn, the pinion and gear can be installed on the opposite side of the tractor, providing the correct backlash can be maintained. Refer to Par. 2, "SPECIFICATIONS."

6. Inspect the sprocket carrier (Illust. 16), for worn splines. Replace all bent or damaged oil seal guards and dirt deflectors.

7. Replace all "O" rings and gaskets with new ones.

8. Inspect the track frame pivot oil seal (56 or 57, Illust. 11 or 12) and sprocket carrier oil seal (22 or 23). Both of these seals are diaphragm type (Illust. 27). The diaphragm must be free of cracks, holes or general deterioration. The sealing washer should protrude from the seal to prevent metal to metal contact with the bearing retainer. The friction or sealing

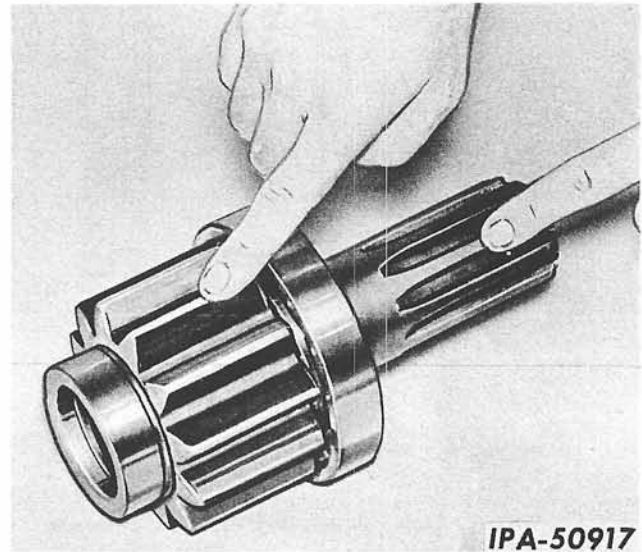

Illust. 26 - Inspecting Pinion Teeth and Splines (Wide Tread Shown).

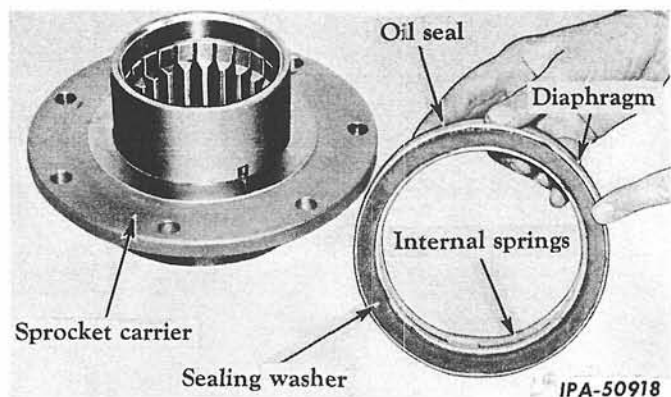

Illust. 27 - Inspecting Diaphragm Type Oil Seals.



## SPROCKET DRIVE

surface of this washer should be free of glaze and high spots for good sealing. Compress the seal to be sure that the internal springs expand it evenly to its free width and that no springs are broken. Replace the entire oil seal with a new one if examination indicates any part not fit for service.

## 10. REASSEMBLY AND INSTALLATION

## Regular Tread

NOTE: Use all new oil seals, gaskets and oil seal rings in the reassembly. Also, on the old "6" SERIES, if the inner housing was removed, install a new "O" ring seal on the pivot shaft next to the main frame (Illust. 28), before installing the inner housing to the main frame.

1. If the pinion shaft was removed, insert the pinion shaft into position through the steering clutch compartment and install the steering clutch and brake as outlined in Section 7. Use a jack through the bottom opening in the main frame to support the weight of the clutch, also to help center the pinion shaft in the bore of main frame to facilitate the installation of the inner housing to the main frame.

2. Reassemble the parts of the pinion inner bearing in the reverse order of their disassembly, and install assembly to the inner housing. (Refer to Illust. 11, parts 2 through 7; or Illust. 12, parts 2 through 6.) Install a new oil soaked seal (4) in the bearing retainer so that the lip side of the seal faces outward toward the bearing.

NOTE: On the 6, 6(61) AND 6 (62) SERIES having roller bearings, install the outer race of the pinion inner bearing into the bearing cage so that the identification groove around the outer race will be toward the flange side of bearing cage when installed. Drive or press in the outer race until it is flush with the bearing cage surface opposite the flange.

On the older 6 SERIES, press the pinion inner bearing into the bearing cage until it is flush with the cage surface opposite the flange side.

On 9, 9 (91) AND 9 (92) SERIES, press the pinion inner bearing into the bore of inner housing until it is flush with the pinion side of the housing.

3. Install the inner housing to the main frame. See that the pinion inner bearing retainer (2) fits evenly around the shoulder of the pinion shaft. Drive the inner housing against the main frame and secure with nuts and cap screws.

4. Install the inner bearing (15) into the sprocket drive gear. 6, 6 (61) AND 6 (62) SERIES with roller bearings, install the outer race into the drive gear so that the identification groove will be TOWARD the tractor; install the inner race on the pivot shaft to butt against the inner housing.

9, 9 (91) AND 9 (92) SERIES with roller bearings, install the outer race in the sprocket drive gear so that the identification groove will be AWAY FROM the tractor; install the inner race on the pivot shaft so as to butt against the inner housing.

5. Install the sprocket drive gear onto the pivot shaft and add the bearing spacer (16) to help align the bearing with the pivot shaft during the final installation when seating against the inner housing.

6. Install the pinion onto the pinion shaft to engage the splines and to mesh the teeth with the sprocket drive gear. However, before installing the pinion on the 6, 6(61) and 6(62) SERIES, drive the inner race of the pinion inner roller bearing into position on the pinion shaft. Place the pinion on the pinion shaft, then drive the inner race of the pinion outer roller bearing onto the end of pinion shaft. The bevel edge of the inner race should face away from the pinion to receive the outer race when the outer housing is installed.

On the 9, 9(91), 9(92) and old 6 SERIES, drive in the pinion to seat the shoulder into the ball bearing previously installed in the inner housing.

7. Install the pinion outer bearing in the outer housing.

6 (61) AND 6 (62) SERIES: Drive the outer race into the bore of the outer housing. The identification groove around the outer race should be toward the bearing cap, when the race is installed.

OLDER 6 SERIES: Install the outer race into the bore of the outer housing, using the two piece ring retainers to hold it in position.

9, 9(91) AND 9(92) SERIES: Press the pinion outer ball bearing into the outer housing until it is seated in the bore.

8. Install the outer housing with a new gasket in place, by passing it over the pivot shaft and, aligning the pinion outer bearing with the pinion, drive the housing evenly to seat the pinion

Continued on next page.



SPROCKET DRIVE

10. REASSEMBLY AND INSTALLATION - Continued

Regular Tread - Continued

outer ball bearing on the shoulder of the pinion for the 9, 9 (91) AND 9 (92) SERIES. Roller type bearings should assemble easily, providing the outer housing is forced into position evenly to prevent binding. Secure the outer housing to the inner housing with nuts and cap screws.

9, 6, 6 (61) AND 6 (62) SERIES: Install the pinion outer bearing retainer nut on the pinion shaft and tighten the nut to specified torque. (Refer to Par. 2, "SPECIFICATIONS.") Use a new nut lock, run on the lock nut and tighten, then bend the lips of nut lock against both nuts. Also install the "O" ring and bearing cap.

9, 9 (91) AND 9 (92) SERIES: Install the pinion outer bearing retainer washer and secure with two lock washers and cap screws. Tighten the cap screws to specified torque. (Refer to Par. 2, "SPECIFICATIONS.") Install the "O" ring and outer bearing cap.

10. Place a new gasket on the peg side of oil seal 22 or 23, Illust. 11 or 12). Dip the surface of sealing washer in oil and install the oil seal by inserting the pegs into the holes in the outer housing. Attach the oil seal guard to the outer housing with lock washers and cap screws.

11. Install the sprocket carrier (with dirt deflector attached) to the drive gear carrier, using care when passing the sprocket carrier hub through the diaphragm type oil seal installed to the outer housing. Tap the carrier with a soft hammer to seat it properly. Add the nut lock and nut to the drive gear carrier threads, and using a special socket wrench SE-1184-1 (Illust. 15), tighten the nut to specified torque. (Refer to Par. 2, "SPECIFICATIONS.") Bend the lips of the nut lock against the nut.

12. Install the drive gear outer bearing and cage against the sprocket carrier. Be sure the "O" ring is in place around the bearing, if bearing was removed from the cage. Install the drive gear outer bearing retainer and pivot oil seal dirt deflector over the bearing cage and secure all three to the sprocket carrier with lock washers and cap screws.

NOTE: If the sprocket was removed from the sprocket carrier during disassembly, install the sprocket to the sprocket carrier before attaching the pivot oil seal dirt deflector.

13. Complete the installation of the remaining parts, from and including the pivot oil seal (56 or 57) to the sprocket shield (65 or 64, Illust. 11 or 12), as outlined under Par. 6, "SPROCKET INSTALLATION."

14. Refill the sprocket drive with the recommended grade and quantity of lubricant. (Refer to the Operator's Manual.)

11. REASSEMBLY AND INSTALLATION

Wide Tread

6, 6 (61), 9, 9 (91) AND 9 (92) SERIES: The installation procedure for the wide tread tractors is the same as that for the regular tread outlined in the preceding Par. 10, except for the reassembly and installation of the pinion shaft, pinion, and the sprocket drive carrier, Illust. 11 or 12. To install the carrier assembly, proceed as follows:

1. Reassemble the steering clutch support bearing parts to the pinion shaft in the reverse order of their disassembly (Illust. 25). (Refer to parts 29 to 34, Illust. 11, or parts 30 to 41, Illust. 12.) Install a new oil soaked seal (32 or 33) in the bearing retainer so that the lip side of the seal faces outward toward the bearing.

Tighten the bearing nuts (34, Illust. 11 or 40, Illust. 12) to specified torque (refer to Par. 2, "SPECIFICATIONS") and bend the lips of nut lock to lock both nuts. The use of a new nut lock is recommended.

6 (62) SERIES ONLY (Illust. 11): Install the steering clutch bearing support assembly to the sprocket drive carrier. Press ball bearing (33) into bearing cage (37). Install the cage into the bore of drive so the oil passage in the cage is at the bottom when the bolt holes are aligned. Place a new gasket (36) on the bearing cage. Install the bearing retainer (31) to match the slot with the oil passage in the bearing cage, and secure the assembly to the drive carrier with the cap screws and lock washers.

2. NOT 6 (62) SERIES: Install the pinion inner bearing (38 or 45) into bearing cage (39 or 46). Pass the assembly through the larger upper bore in sprocket drive carrier for installation in the smaller opposite bore. Secure the flange of the bearing cage to the inside of the outer wall with lock washers and cap screws. See NOTE, as the procedure varies.





NOTE: 61 AND LATER 6 SERIES with roller bearings. Install the outer race into the bearing cage to seat against the shoulder. The identification groove around the race should be toward the flange side of cage. Then install the assembly to the carrier as above.

OLDER 6 SERIES with ball bearings. Press the bearing into the bearing cage to seat against the shoulder. Then press the bearing assembly onto the splined end of pinion so bearing cage flange is toward the spline. Then install the pinion and bearing assembly as above, but use a new gasket between the bearing cage and the carrier if a gasket was removed during disassembly.

9 (91) AND 9 (92) SERIES: Press the bearing into the bearing cage to seat against the shoulder. Press the bearing assembly onto the splined end of pinion so the bearing cage flange is toward the spline. Then install the pinion and bearing assembly as above, using a new gasket between the bearing cage and the carrier if a gasket was removed during disassembly. Add bearing retainer (44, Illust. 12) and secure the retainer (44) with the bearing cage flange to the carrier as above.

6 (62) SERIES ONLY (Illust. 11): Install the sprocket drive carrier to the main frame, but first insert the bearing cage (39) only, into its bore in the inner wall to keep it in position during the installation of the sprocket drive carrier. Raise the drive carrier (41) and pass it over the pivot shaft (60), then the assembled bearing support onto the pinion shaft (29). Use the bearing cage flange OD to pilot the drive carrier into position against the main frame. Install the cap screws, nuts and lock washers and tighten evenly to draw up and secure the drive carrier to the main frame.

3. 6, 6(61), 9, 9(91) AND 9(92) SERIES (Illust. 12): Press the bearing cage (37 or 42), with gasket, into the sprocket drive carrier, be sure that the oil hole in the cage will be at the bottom and that the cap screw holes line up.

6 (62) SERIES ONLY (Illust. 11): Arrange to suspend the bearing cage (39) inside the drive carrier within reach of the opening when the

bearing cage is removed from its bore. Remove the bearing cage (39) from its bore, insert spacer (33A) through the opening and onto the pinion shaft (29). Install bearing retainer nut (34) through the opening and onto the pinion shaft, then tighten to the special torque shown in Par. 2, "SPECIFICATIONS." Install a new nut lock (35) and jam nut (34) and bend the lug to lock into position.

4. 6, 6(61) 9, 9(91) AND 9(92) SERIES: Position the sprocket drive carrier on the pivot shaft, align the cap screw holes and force the carrier against the main frame. Install the attaching bolts and nuts, tightening them evenly. Be sure to install the cap screws between the webs on the inside of the carrier.

6 (62) SERIES ONLY (Illust. 11): Raise the bearing cage (39) and pull it into its bore. Install the cap screws and lock washers to secure the bearing cage to the inner wall of the sprocket drive carrier.

5. 6, 6(61), 9, (91) AND 9(92) SERIES: Install the pinion shaft assembly through the steering clutch compartment with a new gasket (35 or 36) in position. See that the oil passage of the bearing retainer is at the bottom to line up with oil hole in bearing cage when the cap screw holes are aligned. Push the pinion shaft in to engage the splines of the pinion previously installed as outlined in step 2 for the "9" and older "6" SERIES. Drive the pinion shaft, using a soft hammer around the flange bore, to start the bearing into the bearing cage positioned in the carrier. The attaching cap screws may be used to pull the assemblies together. Refer to Illust. 24 for removal. Install and tighten the cap screws evenly through the access holes in the pinion shaft flange.

6 (62) SERIES ONLY (Illust. 11): Install roller bearing outer race (38) until it bottoms on shoulder of the bearing cage (39). The identification groove around the race should be toward the flange side of the cage.

6. 6, 6(61), 9, 9(91) AND 9(92) SERIES: Reinstall the steering clutch and brake. (Refer to Section 7.)

Continued on Next Page

**11. REASSEMBLY AND INSTALLATION-Wide Tread-Continued**

6 (62) SERIES ONLY (Illust. 11): Install the sprocket drive pinion (40) with bearing inner races (38 and 9) installed at each side of pinion gear. If new bearings are required the inner races should be pressed on each shoulder of the pinion gear so the bevel surface of the races face away from the gear teeth. Insert the splined shaft of the pinion gear (40) through the outer race of inner bearing (38) to engage the splines of pinion shaft (29).

7. 6, 6(61), 9, 9(91) AND 9(92) SERIES: Complete the installation of the pinion, pinion outer bearing, outer housing and sprocket assembly as outlined under "Regular Tread."

6 (62) SERIES ONLY (Illust. 11): If a new pinion gear outer bearing (9) is required, press the outer race into the bore of outer housing (10) so the identification groove around the race will be at the cap end. Install new "O" ring (12) and the bearing cap (13) to the outer housing.

The following steps 8 through 16 for 6 (62) series (Illust. 11):

8. Install drive gear (17) on the pivot shaft (60). If the inner bearing (15) was removed, install a new outer race in the gear so the identification groove around the race is toward the tractor. Press the bearing outer race into the gear hub and a new bearing race on the pivot shaft to butt against the main frame.

9. Pass the bearing spacer (16) over the pivot shaft and into the long hub of the drive gear until the spacer bottoms against the bearing in the short hub.

10. Install a new gasket (18) onto the sprocket drive carrier (41). Install the outer housing (19) on the sprocket drive carrier to align with the dowel pins. Install all cap screws, nuts and lock washers, and tighten alternately to draw the sections together evenly.

11. Place a new gasket (22) on the pin side of oil seal (23). Dip the surface of sealing washer in oil and install the oil seal by inserting the pins into the holes of the sprocket drive carrier. Attach the oil seal guard (21) to the carrier with lock washers and cap screws, if it was removed.

12. Install the sprocket carrier (47), with the dirt deflector (25) and all bolts (24) assembled, to the long hub side, to engage the splines of drive gear (17). Install the nut lock (48) and carrier nut (49) on the hub of drive gear (17). Tighten the nut to the required torque shown in Par. 2, "SPECIFICATIONS" and bend the lugs on nut lock.

13. Press ball bearing (52) into bearing cage (51) until seated against the shoulder, if it was removed. Install "O" ring (50) to the groove around the bearing cage, and "O" ring (53) into the recess in bearing cage around the edge of installed bearing (52). Pass this bearing assembly over the pivot shaft, insert the cage into sprocket carrier (47) and the bearing onto the pivot shaft shoulder as far as possible without forcing.

14. Install bearing retainer (54), recess toward the outer bearing, and dirt deflector (55) over the pivot shaft and against the bearing cage (51). Line up the bolt holes, install the lock washers and cap screws. Alternately tighten the cap screws to draw up the assembly evenly to the sprocket carrier hub (47).

15. Install the sprocket (46) onto the bolts extending through the hub of the sprocket carrier, add the external tooth washers and nuts. Tighten the hub bolt nuts to the torque shown in Par. 2, "SPECIFICATIONS."

16. Complete the installation of the remaining parts as outlined under Par. 6, "SPROCKET INSTALLATION."



## 12. PIVOT SHAFT REPLACEMENT

The pivot shaft is pressed through the main frame and supports the sprocket drive gears and the rear end of the track frames (Illust. 28). The shaft is positioned and held from turning by set screws and lock nuts at the rear of the main frame.

If necessary to replace, the shaft must be pulled out of the main frame. This requires a complete disassembly of both sprocket drives. The pivot shaft can be removed or installed most easily with pivot shaft removing and installing set, number Y-3100-C6 for all "6" SERIES or Y-3100-D for all "9" SERIES Crawler Tractors. Refer to "SERVICE TOOLS" manual, ISS-1002 for descriptions and instructions for the use of this tool.

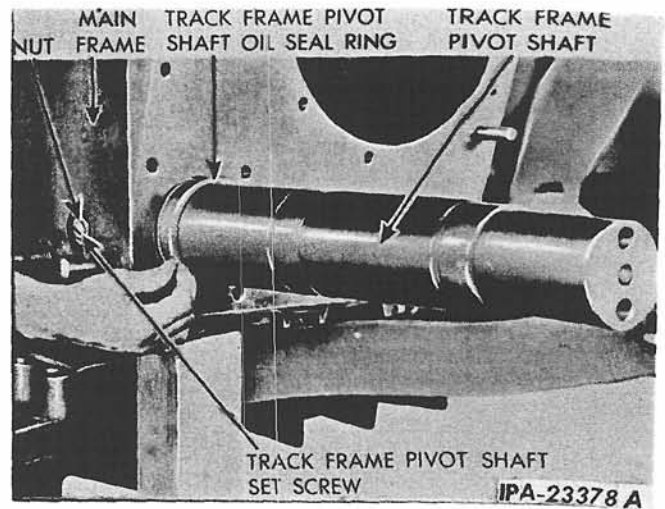

Illust. 28 - Pivot Shaft Replacement